

12.02.2024

CW

Version 1.en

TEST REPORT No. 2024-01-0036-B2

Initial type testing (ITT) according to DIN EN 14351-1 : 2016-12 “Windows and doors – Product standard, performance characteristics – Part 1: Windows and external pedestrian doorsets; German version EN 14351-1:2006+A2:2016”

Project No.	2024-01-0036
Applicant	Emre Alüminyum Yapı San. Tic. A.Ş İshaklı Mahallesi Serinsu Caddesi Beykoz / İstanbul Turkey
Conducted tests	Verification of mandated characteristics - Air permeability - Watertightness - Resistance to wind load
Type	4-leaf balcony glazing (1 hinged door and 3 sliding units), made of thermally separated aluminium profiles, with double sealed with silicone, two sealing levels of finned brush seals all round, EPDM seals in certain sections
Product designation	Huun Balcony Glazing Thermal
Tested by	C. Würfel (personnel supplied: Y. ALTUĞ)

This test report comprises 6 pages and the following attachments:

- Attachment 1: Data sheets (4 pages)
- Attachment 2: Photos (12 pages)
- Attachment 3: Technical documentation according to Section 2.2 (30 pages)
- Attachment 4: Change index (1 page)

PfB GmbH & Co. Prüfzentrum für Bauelemente KG

Ein Unternehmen der TÜV NORD GROUP

Lackermannweg 24
D - 83071 Stephanskirchen
+49 (0) 80 36 / 674947 0
info@pfb-rosenheim.de
www.pfb-rosenheim.de

AG Traunstein HRA 8871
AG Traunstein HRB 16490
phG PfB Verwaltungs GmbH
Geschäftsführung:
Matthias Demmel, Dr. Christoph Sinder

Prüfstelle nach EN ISO/IEC 17025
Zertifizierungsstelle nach EN ISO/IEC 17065
PÜZ-Stelle nach
Landesbauordnung BAY 33
Notified Body No. 1644



CONTENTS

	Page	
1	Scope	3
2	Test samples	3
2.1	Sampling	3
2.2	Technical documentation	3
2.3	Technical data of the test sample	3
2.3.1	Documentation of the test sample	3
3	Test and measuring equipment	4
4	Test	4
4.1	Test period	4
4.2	Test procedure and test results	4
4.2.1	Applicable standards	4
4.2.2	Air permeability test acc. to DIN EN 1026	5
4.2.3	Watertightness test acc. to DIN EN 1027	5
4.2.4	Test of resistance to wind load according to DIN EN 12211	5
5	Summary	5
6	Classification of the test results	6
7	Scope	6
8	General requirements	6

Attachments

1 Scope

With the delivery of the test sample the applicant commissioned the **PfB** “Prüfzentrum für Bauelemente” to test the applicant's sample for the characteristics listed on page 1 under “Conducted Tests”.

2 Test samples

2.1 Sampling

The required test sample was delivered by the producer to “Pfb Yapı Malzemeleri Test Laboratuvar Hiz.San. ve Tic.Ltd.Sti.” in Turkey. The sample was delivered mounted in a four-sided subframe.

2.2 Technical documentation

The following technical documents of the test sample were submitted to the **PfB**. They have been provided with a **PfB** endorsement and are attached to this test report. The applicant is responsible for the correctness and accuracy of the data and information provided. The information and data provided were reviewed by the **PfB** on a random basis.

- Checklist sampling report (1 page)
- Checklist technical documentation (3 pages)
- Technical drawings (26 pages)

2.3 Technical data of the test sample

Sample No. 2024-01-0036-P2

Type	4-leaf balcony glazing (1 hinged door and 3 sliding units), made of thermally separated aluminium profiles, with double glazing, glazing joints sealed with silicone.
Dimensions	Frame (W x H): up to 2500 x 1800 mm
Hardware	2 hinges on door 2 guiding rollers locked per sliding units 2 guide rollers per sliding units Roto door handle
Locking condition	Closed, fastened, locked
Gaskets	two sealing levels of finned brush seals all round, EPDM seals in certain sections

Details according to Section 2.2 Technical documentation.

2.3.1 Documentation of the test sample

Digital photos were taken to document the sample. The photos will be retained at the **PfB** for ten years.

3 Test and measuring equipment

Test and measuring equipment used for testing, see also data sheets Attachment 1.

- Window test rig 000442
- Transportable air permeability/
watertightness/wind load test unit 000436

Due to the selection, accuracies and measurement uncertainties of the test and measuring equipment used, the tolerances specified for the standard measurement values are complied with. Measurement uncertainties are not used for correcting the measurement results obtained, the values obtained are not subject to uncertainty of measurement considerations. The test and measuring equipment is subject to the calibration cycle.

4 Test

4.1 Test period

The tests were conducted at “PFB Yapı Malzemeleri Test Laboratuvar Hiz.San. ve Tic.Ltd.Sti.” laboratories in Turkey on 30.01.2023.

4.2 Test procedure and test results

4.2.1 Applicable standards

Requirements and classification standards

- DIN EN 12207 : 2017-03 “Windows and doors – Air permeability – Classification”
- DIN EN 12208 : 2000-06 “Windows and doors – Watertightness – Classification”
- DIN EN 12210 : 2016-10 “Windows and doors – Resistance to wind load – Classification”

Test and calculation standards

- DIN EN 1026 : 2016-09 “Windows and doors – Air permeability – Test method”
- DIN EN 1027 : 2016-09 “Windows and doors – Watertightness – Test method”
- DIN EN 12211 : 2016-10 “Windows and doors – Resistance to wind load – Test method”

4.2.2 Air permeability test acc. to DIN EN 1026

Air permeability was tested in accordance with the requirements of DIN EN 1026.

The air permeability of the samples was tested according to the above standard up to a pressure of 600 Pa, first at positive pressure in the test chamber and then at negative pressure in the test chamber. The air volumes measured at the different pressure steps are documented in the attached data sheet “Air permeability according to DIN EN 1026”. All modifications and all measures taken are indicated in the a.m. data sheet.

For the tables given in the a.m. data sheet, the air permeability values measured for the positive and negative pressures in accordance with DIN EN 1026 have been converted to standard conditions (293 K / 101.3 kPa) for each pressure step specified in the standard.

The averages determined in the tests at positive and negative pressures were calculated relating to the joint length and relating to the surface area of the test sample. They are given as numerical values in the table of the data sheet and in the corresponding diagrams.

The air permeability repeat test conducted after the wind load resistance test did not show any significant deviation of the results as compared to the initial test.

4.2.3 Watertightness test acc. to DIN EN 1027

Watertightness was tested in accordance with the requirements of DIN EN 1027.

Watertightness was tested up to the specified test pressure or the test pressure at which repeated or continuous water leakage to the area to be protected was observed. Water leakage or achievement of the specified test pressure without water leakage were recorded.

The test results for the sample are documented in the attached data sheets: “Watertightness test according to DIN EN 1027” data sheet. All modifications and all measures taken are indicated in the a.m. data sheet.

4.2.4 Test of resistance to wind load according to DIN EN 12211

Resistance to wind load was tested in accordance with the requirements of DIN EN 12211. The test results are documented in the attached “Resistance to wind load according to DIN EN 12211” data sheet. All modifications and all measures taken are indicated in the a.m. data sheet.

No damage to the sample was observed when subjected to the repeated pressure test. The final safety test (= 1.5 x test pressure P2) was performed on the samples. The test pressures applied were documented in the aforementioned data sheet.

5 Summary

EN 1026	Air permeability tested to	600 Pa
EN 1027	Watertightness tested up to and including 150 Pa	250 Pa
EN 12211	Resistance to wind load tested up to max. rel. deformation	800 Pa 1/162

Locking condition: closed, fastened, locked

6 Classification of the test results

The classification is carried out in the classification reports stated in the cover sheet. Measurement uncertainties were not included in the classification. Classification is based only on the values obtained.

7 Scope

In accordance with Annex E of DIN EN 14351-1 “Determination of characteristics”, the test results determined for the tested samples can be applied directly to construction products of similar design (see also Section 3.4 of the standard in conjunction with Annex A) and of equal or smaller size (e.g. resistance to wind load).

The air permeability and watertightness characteristics are exceptions to the above general rule. In this case, the classes achieved also apply to assemblies of the same type of opening with smaller sizes and larger sizes up to + 50% of the size tested.

However, this only applies if neither the distances of the locking points to the corners nor the distances between the locking points are substantially changed.

However, this extension in size does not apply to the characteristic of resistance to wind load.

8 General requirements

This test report is intended for the applicant only and must not be published, wholly or in part, without the prior permission by both the applicant and the **PfB**.

The classification reports stated on the cover sheet are intended for publication.

The document was digitized and sent to the applicant as a signed PDF file. The PDF file remains stored in the **PfB** for documentation purposes.

This document was written in German and translated into English. In case of any discrepancies between the two language versions, the German version shall prevail.

The test results apply only to the tested sample. A transfer of the test results of this test report to other products from the applicant's tested product family is only permitted if their design and materials correspond to the tested sample and comply with the specifications of this test report.

This test report is issued without prejudice to any rights of third parties, in particular intellectual property rights. The **PfB** shall not be liable for any recourse claims arising from or in connection with the issuance of this test report.

Validity Valid for the validity period of EN 14351-1 : 2006+A2:2016

Dipl.-Ing. (FH) Christoph Geiger
Head of Notified Test Body

Stephanskirchen
12.02.2024

Cornelius Würfel B.Eng.
Responsible Official

Data sheet 1: Air permeability acc. to DIN EN 1026

Sample: 4-leaf balcony glazing, made of aluminium Profiles (1 swing door and 3 slide Elements)
with double glazing, made of aluminium Profiles Date of test: 30.01.2024

Sample No.: 2024-01-0036-P2 Delivery condition

Overall dim. [mm] :	Frame width: 2500 mm	Atmospheric pressure: 1003 hPa
	Frame height: 1800 mm	Temperature: 15 °C
	Unit width: 590 mm	Rel. air humidity: 44 %
	Unit height: 1670 mm	Joint length L: 13,07 m
	Casement width:	Surface area A: 4,50 m ²
	Casement height:	Leakage rate test chamber:

Measuring devices: at 600 Pa, 1m³/h - air volume
For total leakage rates <3m³/h (chamber and test sample together) the chamber leakage rate must be determined.

Locking condition: Closed, fastened and locked

3 pressure pulses: Applied

Table : Air permeability V_0 (corrected to standard conditions: 293 K, 101,3 kPa)

Test pressure difference (Pa)		10	50	100	150	200	250	300	450	600
V1 (positive) (m ³ /h)		11,3	33,1	51,5	63,6	66,9	73,8	85,8	117,2	117,3
V2 (negative) (m ³ /h)		9,0	26,2	40,2	51,6	63,0	74,5	106,5	239,9	360,3
V3 (average) (m ³ /h)		10,1	29,6	45,8	57,6	65,0	74,1	96,2	178,6	238,8
Air permeability relating to joint length L of the element										
V _l 1 (positive) (m ³ /hm)		0,87	2,53	3,94	4,86	5,12	5,65	6,56	8,97	8,97
V _l 2 (negative) (m ³ /hm)		0,69	2,00	3,07	3,95	4,82	5,70	8,15	18,36	27,57
V _l 3 (average) (m ³ /hm)		0,78	2,27	3,51	4,41	4,97	5,67	7,36	13,66	18,27
Air permeability relating to surface area A of the complete element										
V _A 1 (positive) (m ³ /hm ²)		2,51	7,35	11,44	14,13	14,86	16,40	19,07	26,04	26,06
V _A 2 (negative) (m ³ /hm ²)		1,99	5,82	8,93	11,48	14,01	16,55	23,67	53,32	80,07
V _A 3 (average) (m ³ /hm ²)		2,25	6,58	10,19	12,80	14,43	16,48	21,37	39,68	53,07

Notes: Values for 10 Pa test pressure were extrapolated

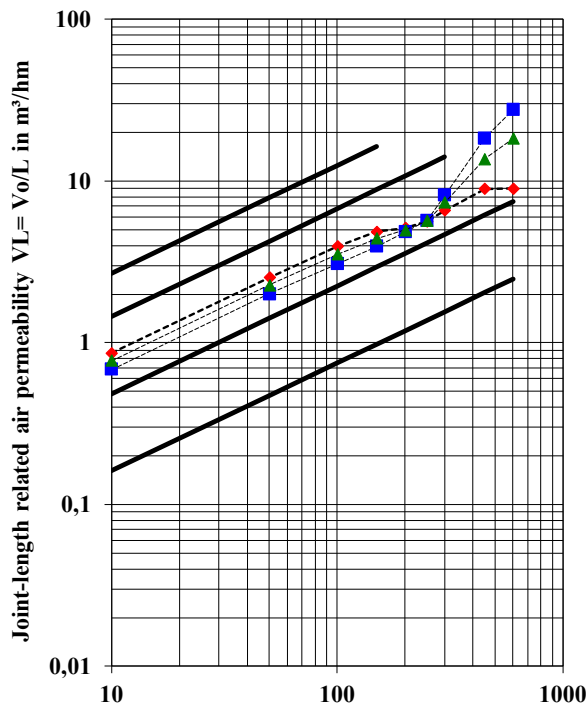

— Classes 1 to 4 acc. to DIN EN 12207
 - - - ◆ - - - VL1 (positive)
 - - - ■ - - - VL2 (negative)
 - - - ▲ - - - VL3 (average)

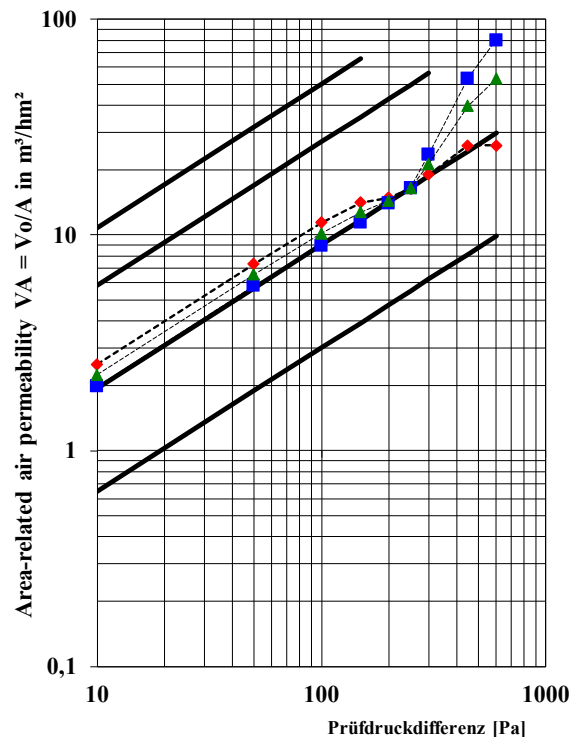

— Classes 1 to 4 acc. to DIN EN 12207
 - - - ◆ - - - VA1 (positive)
 - - - ■ - - - VA2 (negative)
 - - - ▲ - - - VA3 (average)

Data sheet 2: Air permeability acc. to DIN EN 1026

Sample: 4-leaf balcony glazing, made of aluminium Profiles (1 swing door and 3 slide Elements)
 with double glazing, made of aluminium Profiles Date of test: 30.01.2024
 Modifications: changed brush seal, new seal slightly bigger with fin; added silicone on glazing joints
 Sample No.: 2024-01-0036-P2

Overall dim. [mm] : Frame width: 2500 mm Atmospheric pressure: 1003 hPa
 Frame height: 1800 mm Temperature: 15 °C
 Unit width: 590 mm Rel. air humidity: 44 %
 Unit height: 1670 mm Joint length L: 13,07 m
 Casement width: Surface area A: 4,50 m²
 Casement height: Leakage rate test chamber:
 at 600 Pa, 1m³/h - air volume
 For total leakage rates <3m³/h (chamber
 and test sample together) the chamber
 leakage rate must be determined.

Measuring devices:

Locking condition: Closed, fastened and locked
 3 pressure pulses: Applied

Table : Air permeability V_0 (corrected to standard conditions: 293 K, 101,3 kPa)

Test pressure difference (Pa)	10	50	100	150	200	250	300	450	600
V1 (positive) (m ³ /h)	8,0	23,4	38,7	49,9	60,0	67,7	66,5	88,0	88,1
V2 (negative) (m ³ /h)	8,4	24,5	37,5	50,0	60,3	73,6	110,1	257,6	381,5
V3 (average) (m ³ /h)	8,2	24,0	38,1	49,9	60,1	70,6	88,3	172,8	234,8
Air permeability relating to joint length L of the element									
V _L 1 (positive) (m ³ /hm)	0,61	1,79	2,96	3,81	4,59	5,18	5,09	6,74	6,74
V _L 2 (negative) (m ³ /hm)	0,64	1,88	2,87	3,82	4,62	5,63	8,42	19,71	29,19
V _L 3 (average) (m ³ /hm)	0,63	1,83	2,92	3,82	4,60	5,40	6,76	13,22	17,96
Air permeability relating to surface area A of the complete element									
V _A 1 (positive) (m ³ /hm ²)	1,78	5,21	8,60	11,08	13,32	15,04	14,78	19,56	19,58
V _A 2 (negative) (m ³ /hm ²)	1,86	5,45	8,34	11,11	13,41	16,35	24,46	57,24	84,77
V _A 3 (average) (m ³ /hm ²)	1,82	5,33	8,47	11,09	13,36	15,70	19,62	38,40	52,18

Notes: Values for 10 Pa test pressure were extrapolated

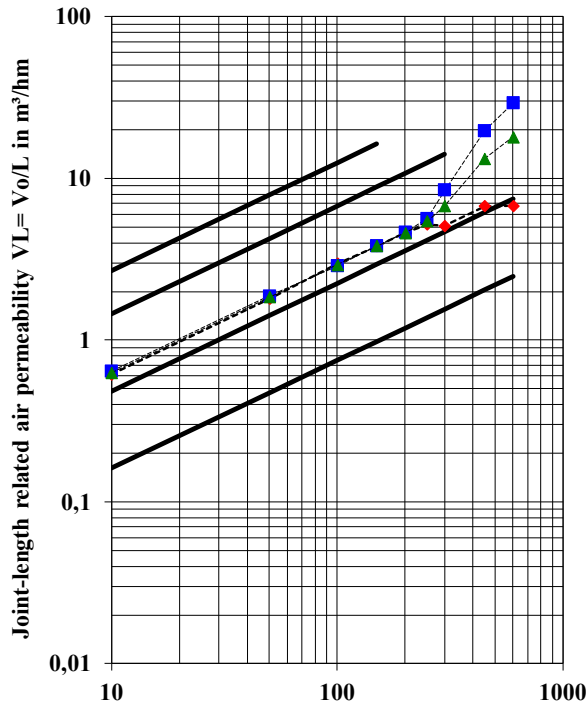

— Classes 1 to 4 acc. to DIN EN 12207
 - - - VL1 (positive)
 - - - VL2 (negative)

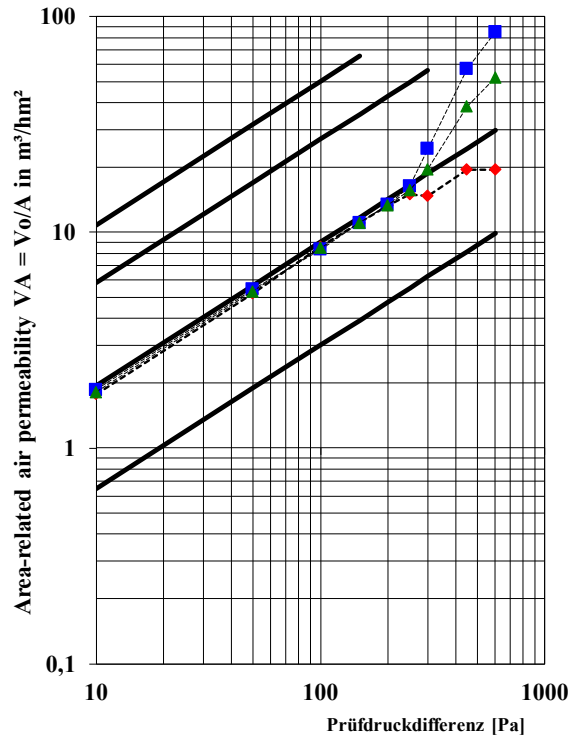

— Classes 1 to 4 acc. to DIN EN 12207
 - - - VA1 (positive)
 - - - VA2 (negative)

Data sheet 3: Watertightness acc. to DIN EN 1027

Sample: 4-leaf balcony glazing, made of aluminium Profiles (1 swing door and 3 slide Elements)
with double glazing, made of aluminium Profiles Date of test: 30.01.2024
Sample No.: 2024-01-0036-P2

Overall dim. [mm] :	Frame width:	2500 mm	Atmospheric pressure:	952 hPa
	Frame height:	1800 mm	Temperature:	18 °C
	Unit width:	590 mm	Rel. air humidity:	44 %
	Unit height:	1670 mm	Joint length L:	13,07 m

Measuring devices:

Closing condition: closed, fastened and locked
3 pressure pulses: yes

No. of nozzles: 4
No. of spray tubes: 1
Total no. of nozzles: 7
Spray method: 1A

Table 1:

Spray method	1A (exposed)				4 nozzles per spray tube			Date of test:	30.01.2024
Test pressure (Pa)	0	50	100	150					
Time t (min)	15	5	5	5					
Pass? Yes-ja / no-nein	ja	ja	ja	nein					
Remark:									
Water leakage:	at 150 Pa after 30 s single drop at bottom of swing sash joint at 150 Pa after 4 m flowing water input from the top of the first slide sash through brush gasket								
Modifications:	None, tested as supplied								

Elevation drawing: Test 1 and 2

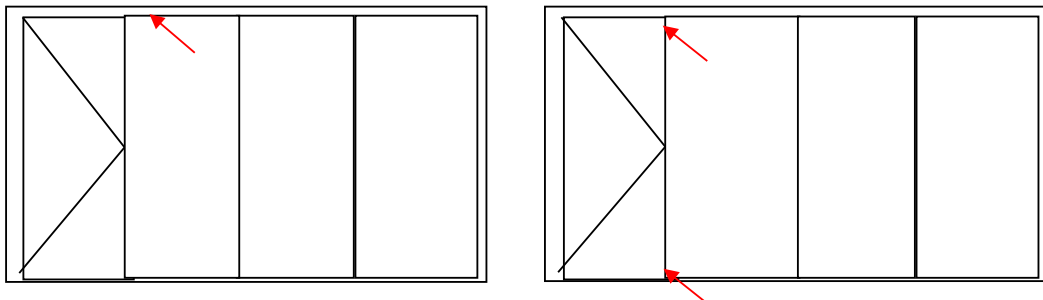

→ = position of water leakage

Table 2:

Spray method	1A (exposed)				4 nozzles per spray tube			Date of test:	30.01.2024	
Test pressure (Pa)	0	50	100	150	200	250	300			
Time t (min)	15	5	5	5	5	5	5			
Pass? Yes-ja / no-nein	ja	ja	ja	ja	ja	ja	ja	nein		
Remark:										
Water leakage:	at 200 Pa after 30 s single drop flowing at the top of the sash, flowing to drainage bottom profile at 250 Pa after 60 s increased drops flowing at the top of the sash, flowing to drainage bottom profile at 300 Pa after 150 s constant flow at swing sash joint, not flowing to drainage bottom profile									
Modifications:	changed brush seal, new seal slightly bigger with fin; added silicone on glazing joints									

Data sheet 4: Resistance to wind load acc. to DIN EN 12211

Sample: 4-leaf balcony glazing, made of aluminium Profiles (1 swing door and 3 slide Elements)
with double glazing, made of aluminium Profiles Date of test: 30.01.2024
Sample No.: 2024-01-0036-P2

Overall dim. [mm] :	Frame width:	2500 mm	Atmospheric pressure:	1003 hPa
	Frame height:	1800 mm	Temperature:	15 °C
	Unit width:	590 mm	Joint length L:	13,07 m
	Unit height:	1670 mm	Surface area A:	4,50 m ²

Measuring devices:

Locking condition: closed, fastened and locked
3 pressure pulses: yes
Elevation drawing:

Span width L
1640 mm

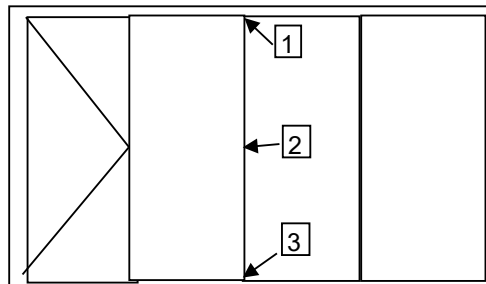

→ = position of meas. point
1 = serial No. of meas. point

Table 1 Test of frontal deflection

Pos. / neg. press. [Pa]	Frontal displacement of meas. points in [mm] under pos. pressure				Frontal displacement of meas. points in [mm] under neg. pressure			
	Meas pt. 1	Meas pt. 2	Meas pt. 3	f	Meas pt. 1	Meas pt. 2	Meas pt. 3	f
400	0,63	4,35	0,77	3,65	0,72	5,66	0,67	4,97
800	1,47	10,40	1,87	8,73	1,41	11,50	1,38	10,11
1200	2,52	17,61	3,52	14,59	1,69	18,46	2,68	16,28
1600				0,00				0,00
2000				0,00				0,00
Limit values	A (L/150)	B (L/200)	C (L/300)		A (L/150)	B (L/200)	C (L/300)	
DIN EN 12210	10,9	8,2	5,5		10,9	8,2	5,5	

max. rel. deformation	1/188	1/162
-----------------------	--------------	--------------

Alternating load $P_2 = P_1 * 0,5$
 $P_2 = 400 \text{ Pa}$
 50 cycles $\pm 400 \text{ Pa}$ without damage

Safety load $P_3 = P_1 * 1.5$
 $P_3 = 1200$
 $\pm 1200 \text{ Pa}$ without damage

Photo 1:
Sample No 2024-01-0036 -P2

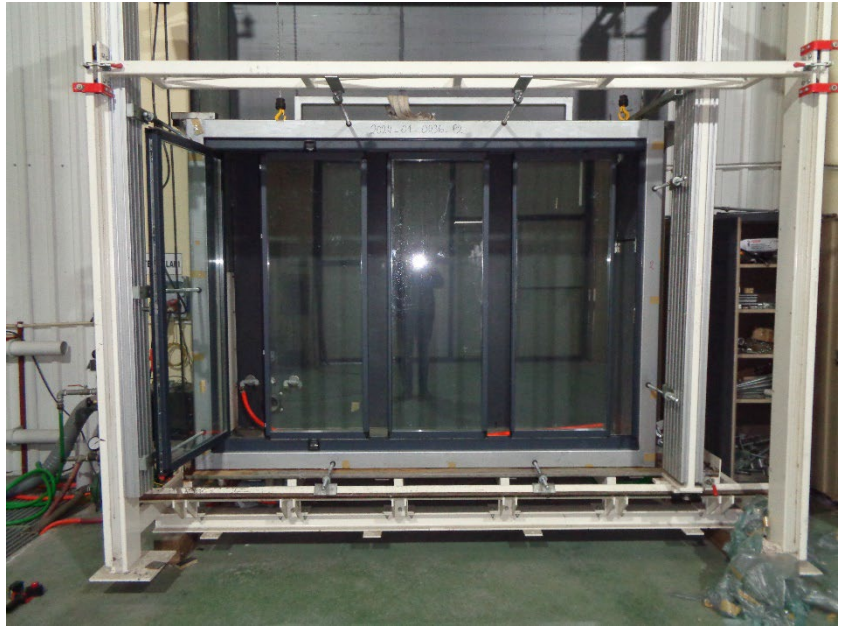

Photo 2:
Sample No. 2024-01-0036 -P2



Photo 3:
Sample No. 2024-01-0036 -P2



Photo 4:
Sample No. 2024-01-0036 -P2



Photo 5:
Sample No. 2024-01-0036 -P2



Photo 6:
Sample No. 2024-01-0036 -P2



Photo 7:
Sample No. 2024-01-0036 -P2



Photo 8:
Sample No. 2024-01-0036 -P2



Photo 9:
Sample No. 2024-01-0036 -P2



Photo 10:
Sample No. 2024-01-0036 -P2



Photo 11:
Sample No. 2024-01-0036 -P2

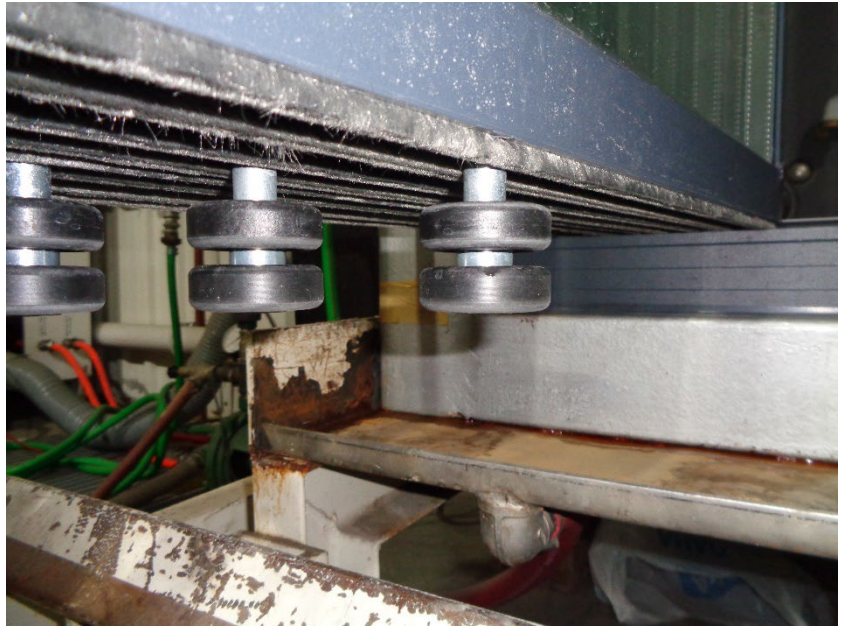

Photo 12:
Sample No. 2024-01-0036 -P2



Photo 13:
Sample No. 2024-01-0036 -P2



Photo 14:
Sample No. 2024-01-0036 -P2

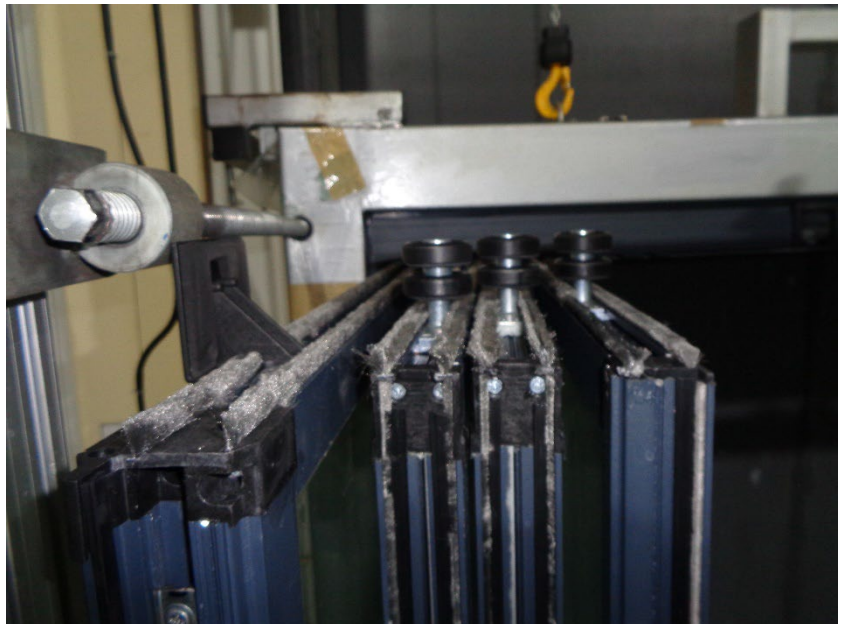

Photo 15:
Sample No. 2024-01-0036 -P2



Photo 16:
Sample No. 2024-01-0036 -P2

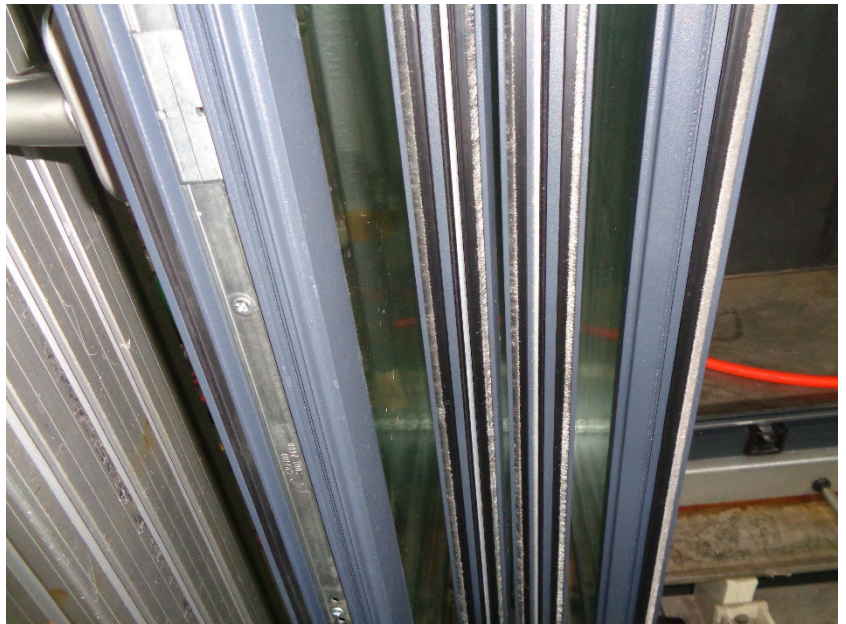

Photo 17:
Sample No. 2024-01-0036 -P2

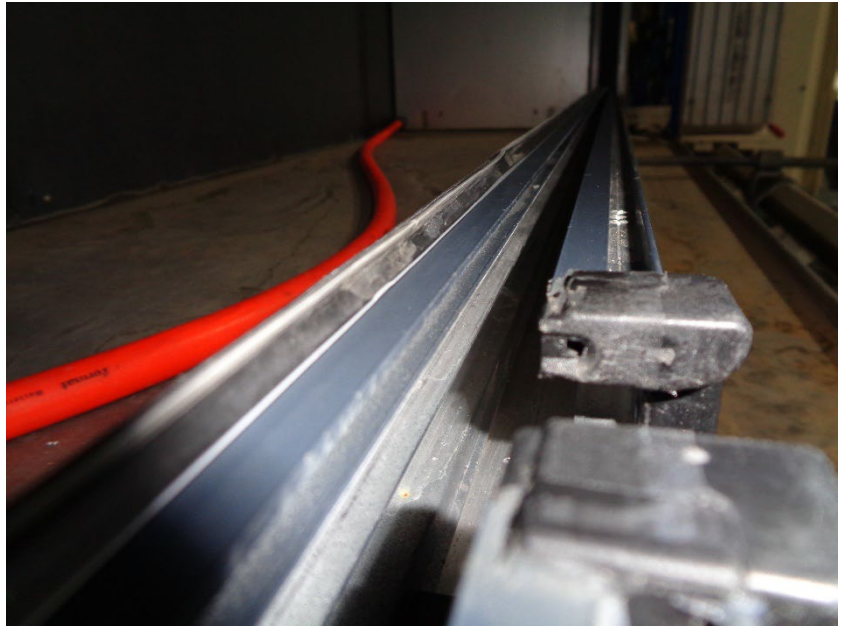

Photo 18:
Sample No. 2024-01-0036 -P2



Photo 19:
Sample No. 2024-01-0036 -P2



Photo 20:
Sample No. 2024-01-0036 -P2



Photo 21:
Sample No. 2024-01-0036 -P2

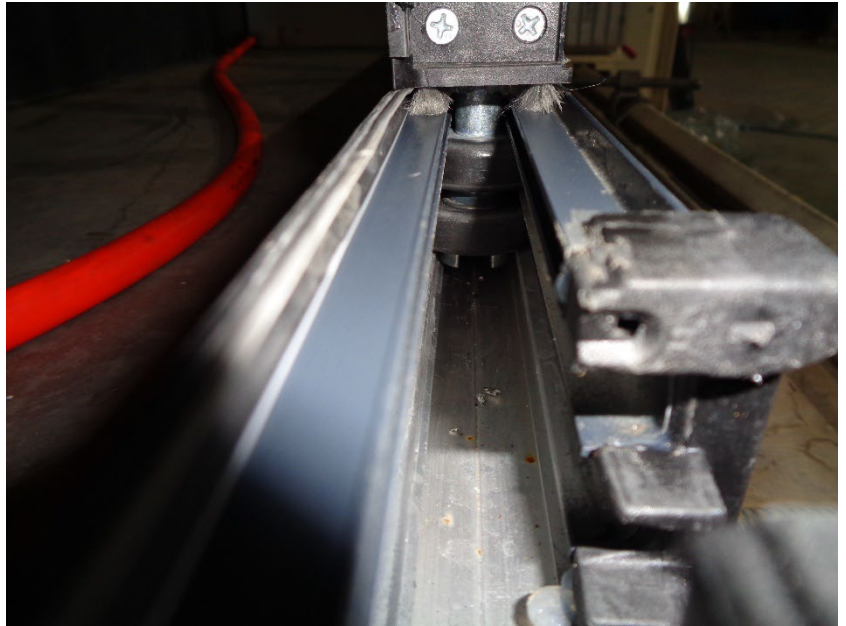

Photo 22:
Sample No. 2024-01-0036 -P2



Photo 23:
Sample No. 2024-01-0036 -P2



Photo 24:
Sample No. 2024-01-0036 -P2





QM Checklist

Prüfzentrum für Bauelemente

Page 1 of 1

CL004 Sampling report

All information is for internal use of PFB only and will not be disclosed to third parties.

Please fill out all fields that apply to your product.

	Applicant	Manufacturer (if different from the applicant)
Company	Emre Alüminyum Yapı San. Tic. A.Ş	
Street	İshaklı Mahallesi Serinsu Caddesi	
Postcode/place	Beykoz / İstanbul	

Aim of the test

(E.g. specification of the class of the performance to be tested)

Type of test or tests to be performed

(E.g.: standard specification, guideline, performance characteristic to be tested)

Description of the test specimen(s)

(Example: Single-leaf door made of wood-based materials with steel frame with P4A light cut-out)

Details of the specimen(s)

Quantity of specimens	
Stack/batch/lot indicator	
Name of the product / product designation of the test specimen(s) (E.g. assignment of a check number)	
Building project (optional)	

Labelling of the specimen(s) by the applicant

Labelling of the specimen(s)	
Place of sampling (Manufacturing plant)	
Date	
Person responsible for sampling	

CL004 Version 2.1

CL004b Checklist technical documentation of windows

Product name	Huun Balcony Glazing Thermal
Element type (like 1-leaf or 2-leaf)	4 Leaf

Measurements

Total size incl. subframe	2700x100
Sash dimensions (W x H)	710x1657 , 622x1657 , 585x1657 , 601.5x1657
Frame dimensions (W x H)	2500x1800
Clear opening dimension (W x H)	2260x1670

Sash frame

Material	Aluminium Profile + Insulating Bars
Profile system	Vertical Sash Profile, Horizontal Sash Profile, Lock Profile, Lock Op
Profile section (W x H)	32x39 , 36x39.4 , 66x50 , 45x39
Handle height	900
Sash frame connection - design (tenon, plug-in connection, welded....)	With Plug-in connection Pvc and screws
Other	

Frame

Material	Aluminium Profile
Profile system	Frame + Pillar
Profile section (W x H)	Frame : 48x65 , Pillar : 50x30
Handle height	
Sash frame connection - design (tenon, plug-in connection, welded....)	With plug-in cpnnection pvc and screws

Rebate

Gap dimensions	
top	
down	
lateral	
forend	

Glazing / Filling

Material (e.g. float)	Tempered Glass , Metal Window Spacer
Structure (glass thicknesses/SZR)	31 mm
Outer dimension (W x H)	710x1657 , 622x1657 , 585x1657 , 601.5x1657
Visible dimension (W x H)	613x1578 , 547x1578 , 533x1578 , 547x1578
glass deuce	Yes
spacer	20 mm

Structure of non-transparent fillings (from inside to outside)

Top layer (inside)	Weather Strip - 9 mm
Insert	
Frame	TPU Seal + EPDM Seal
Reinforcement	PVC / PA6+GF30
Top layer (outside)	Weather Strip - 9 mm

Filling installation

Gasket	
Inside	Weather Strip - 9 mm
outside	TPU Seal + EPDM Seal

Glass retaining strips / panel retaining strips

Material	Aluminium Profile + Insulating Bars
Profile section (W x H)	36x39.4 Profile , 32x17 mm Glass Space
Mounting type (screwed, glued)	Silicon
Mounting distances incl. screw dimensions	3,9x25 mm Screw



QM Checklist

Prüfzentrum für Bauelemente

Seite 3 von 3

Fitting and striker

Type/Designation/Manufacturer	
Mounting/screw type	DIN7982
Number of screws	44
Pin design	
Number of locking pins/latches	
Gearbox mounting	
Screw dimensions	3,9x25 mm
Number of screws	

Gaskets

Type/Designation/Manufacturer	EPDM / HUUN
Material	EPDM + TPU + Weather Strip
Number of sealing levels	24

other

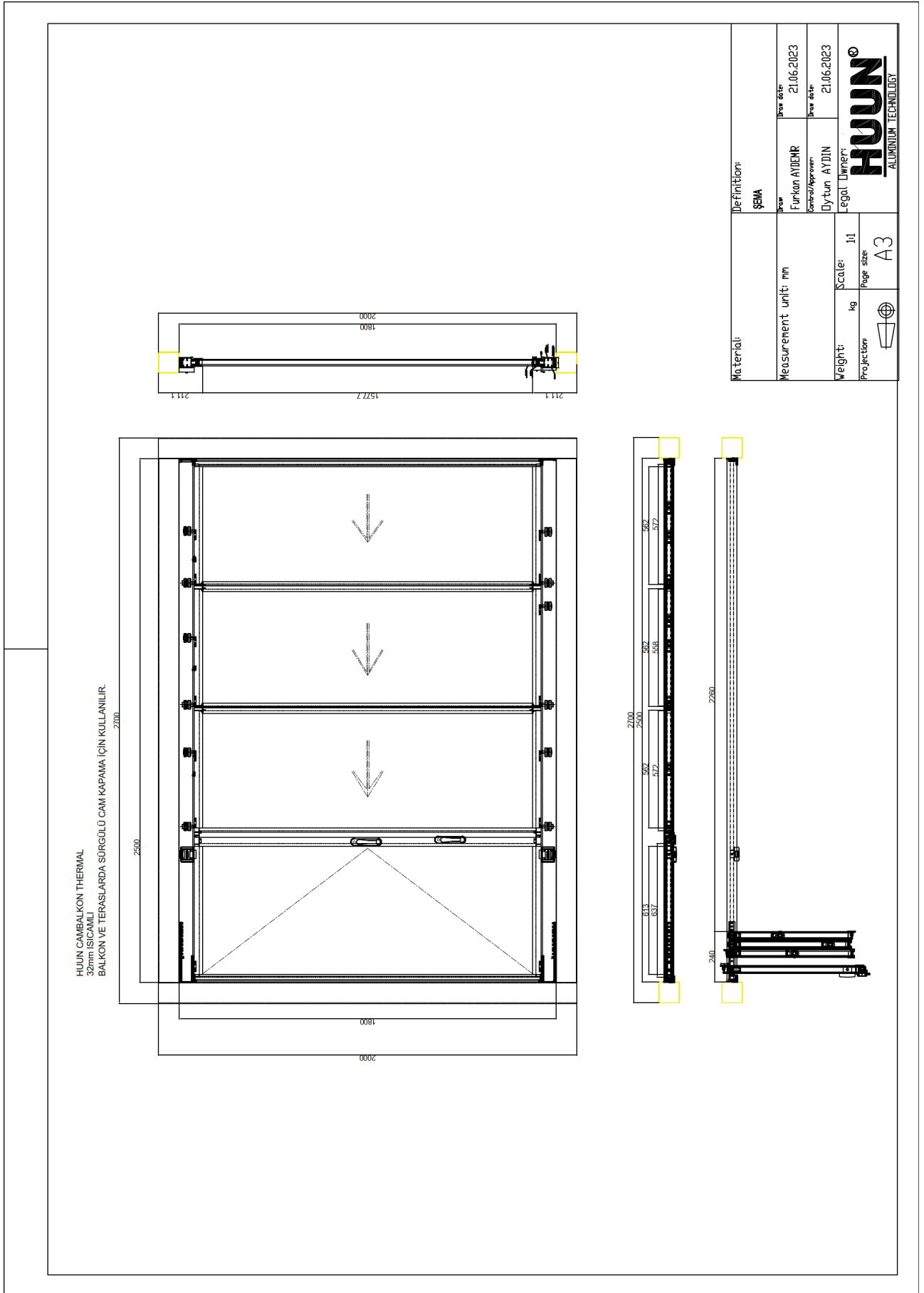

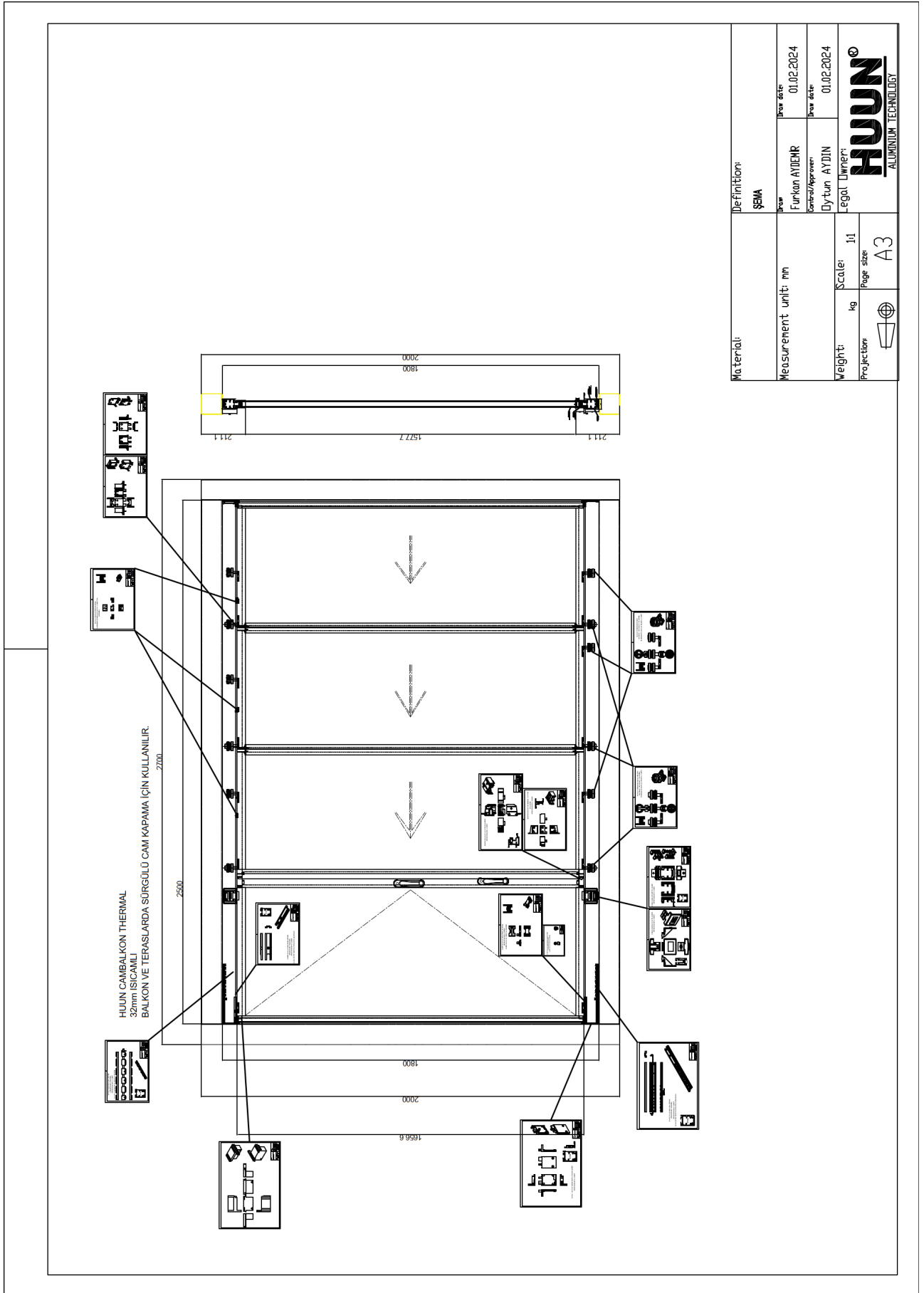

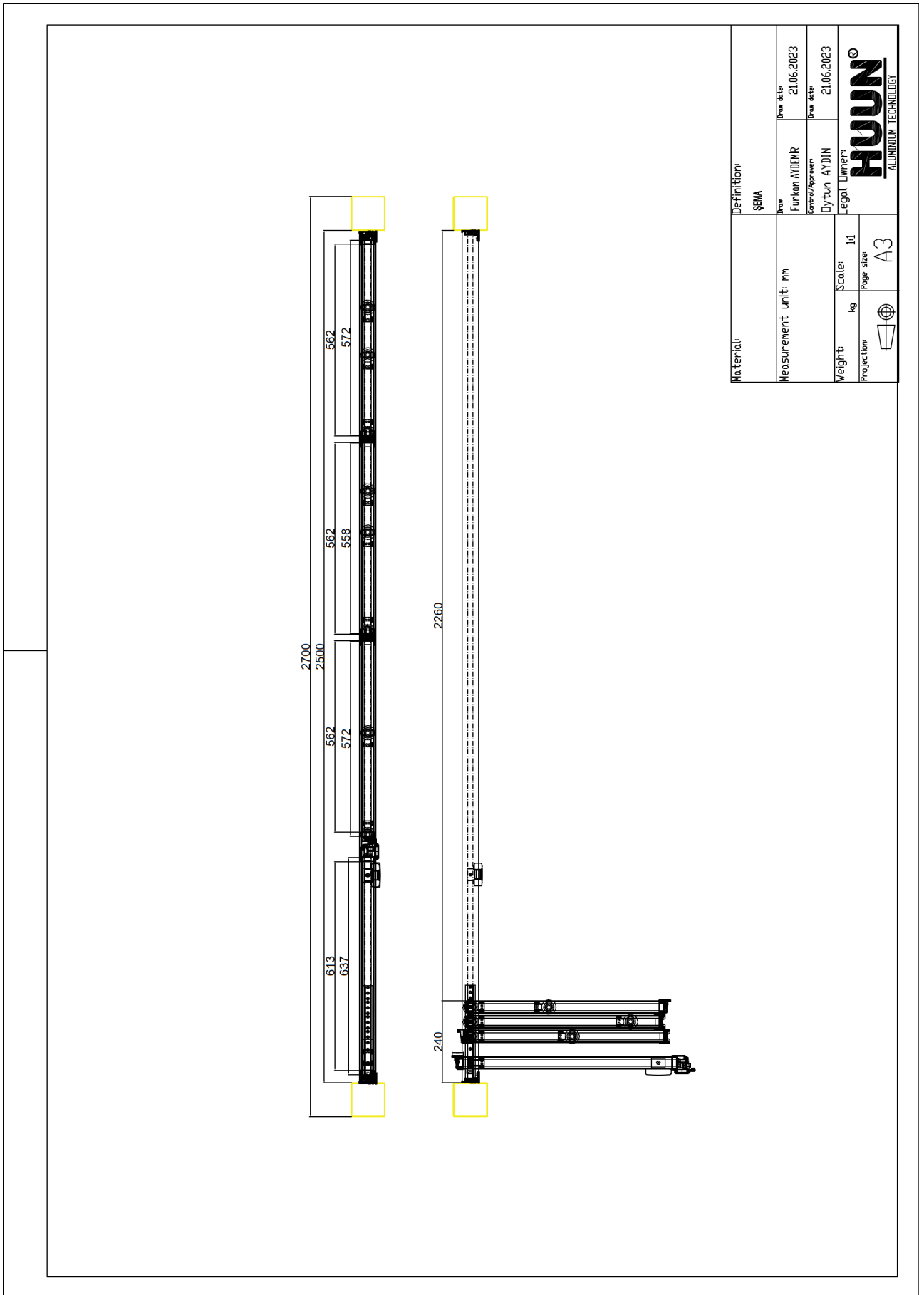

Material:	Definition:	ŞEMA	
Measurement unit: mm	Drawn:	Furkan AYDEMİR	Draw date: 01.02.2024
Weight: kg	Control/Approver:	Dytun AYDIN	Draw date: 01.02.2024
Scale: 1:1	Legal Owner:	HUUN® ALUMINIUM TECHNOLOGY	
Projection: 	Page size:	A3	

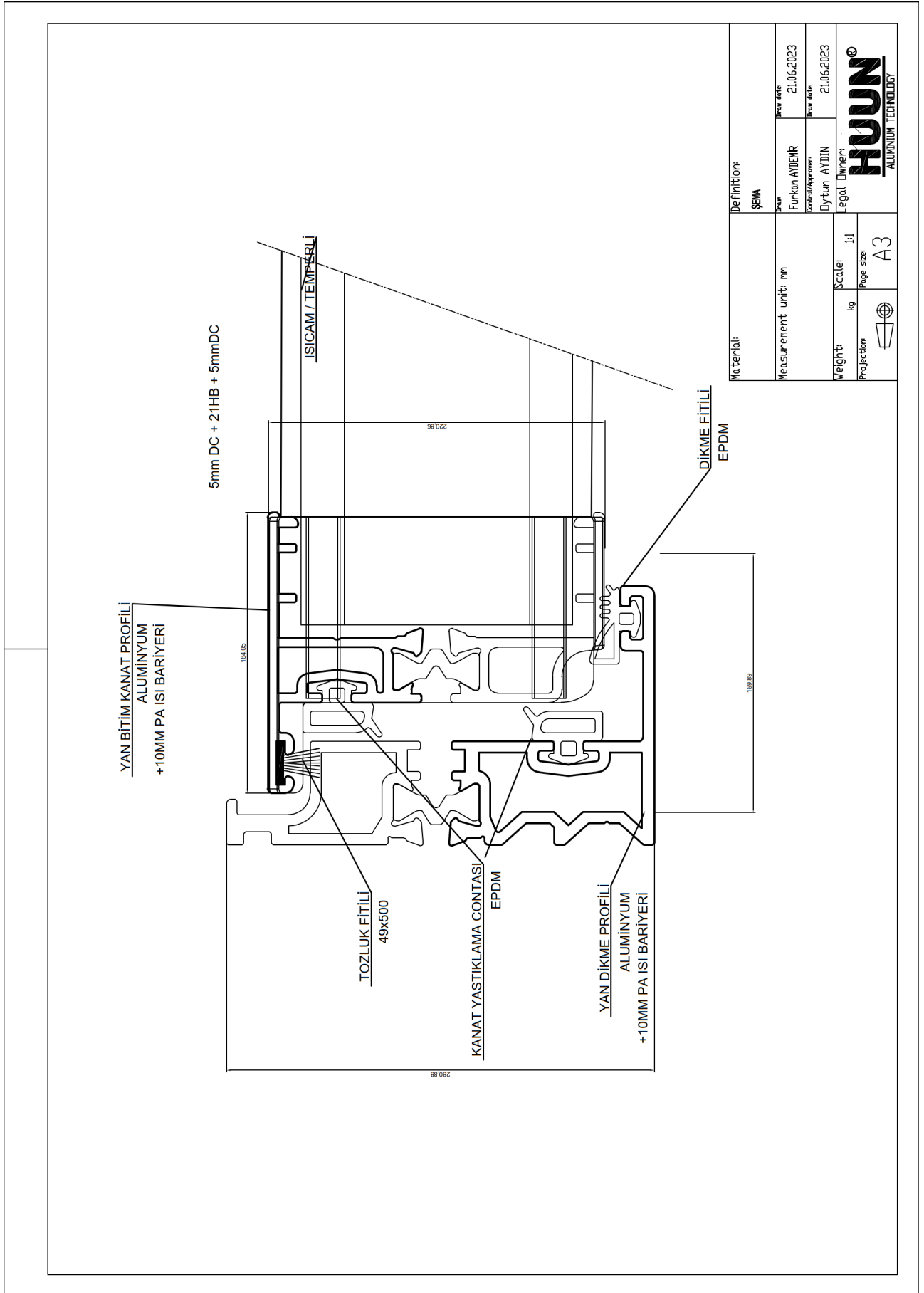

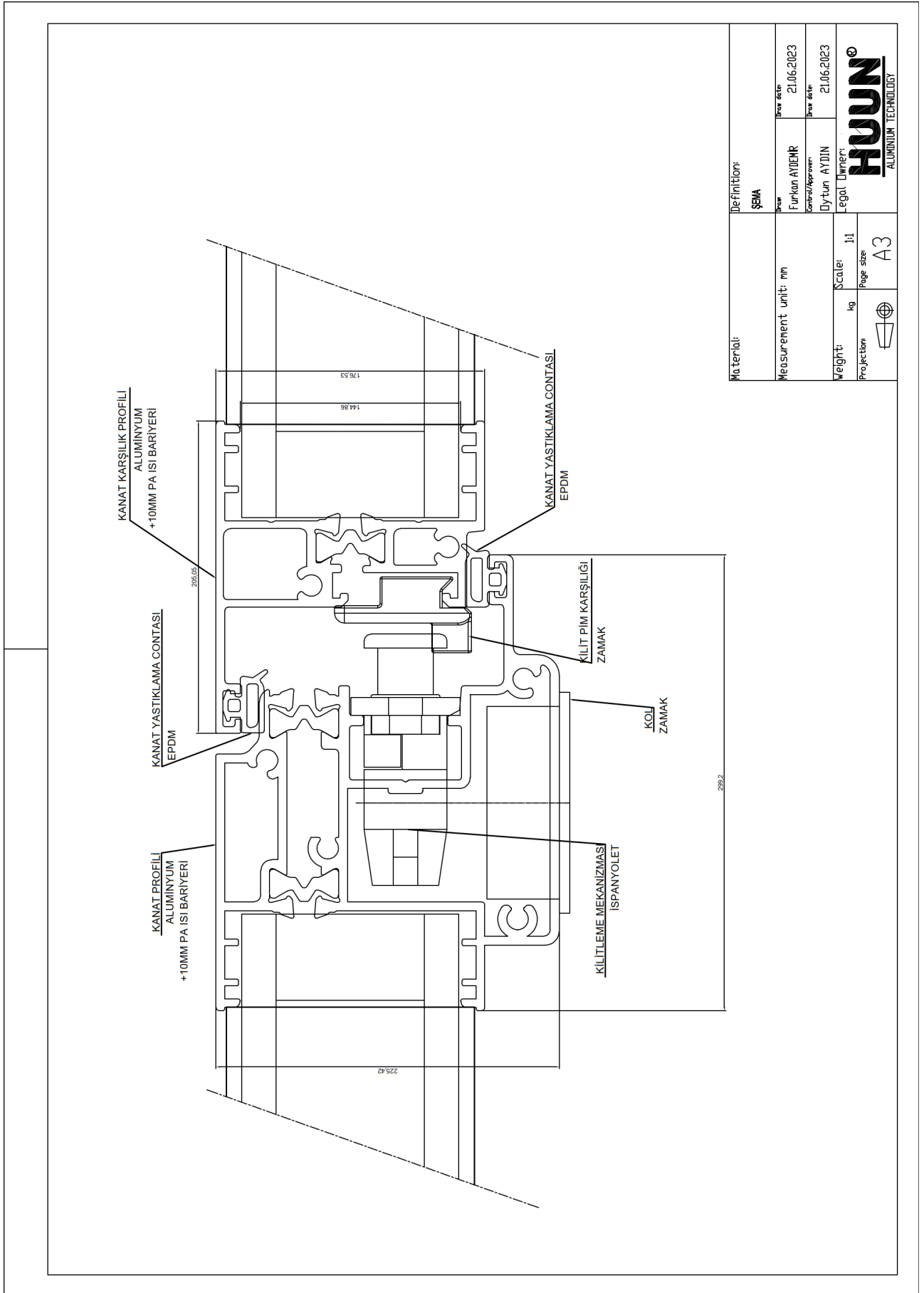



Material:	Definition:
ŞEMA	ŞEMA
Measurement unit: mm	Draw date: 21.06.2023
	Drawn: Furkan AYDEMİR
	Control/Approver: Dytun AYDIN
	Legal Owners: 21.06.2023
Weight: kg	Scale: 1:1
Projection:	Page size: A3
	
	HUNN [®] ALUMINIUM TECHNOLOGY

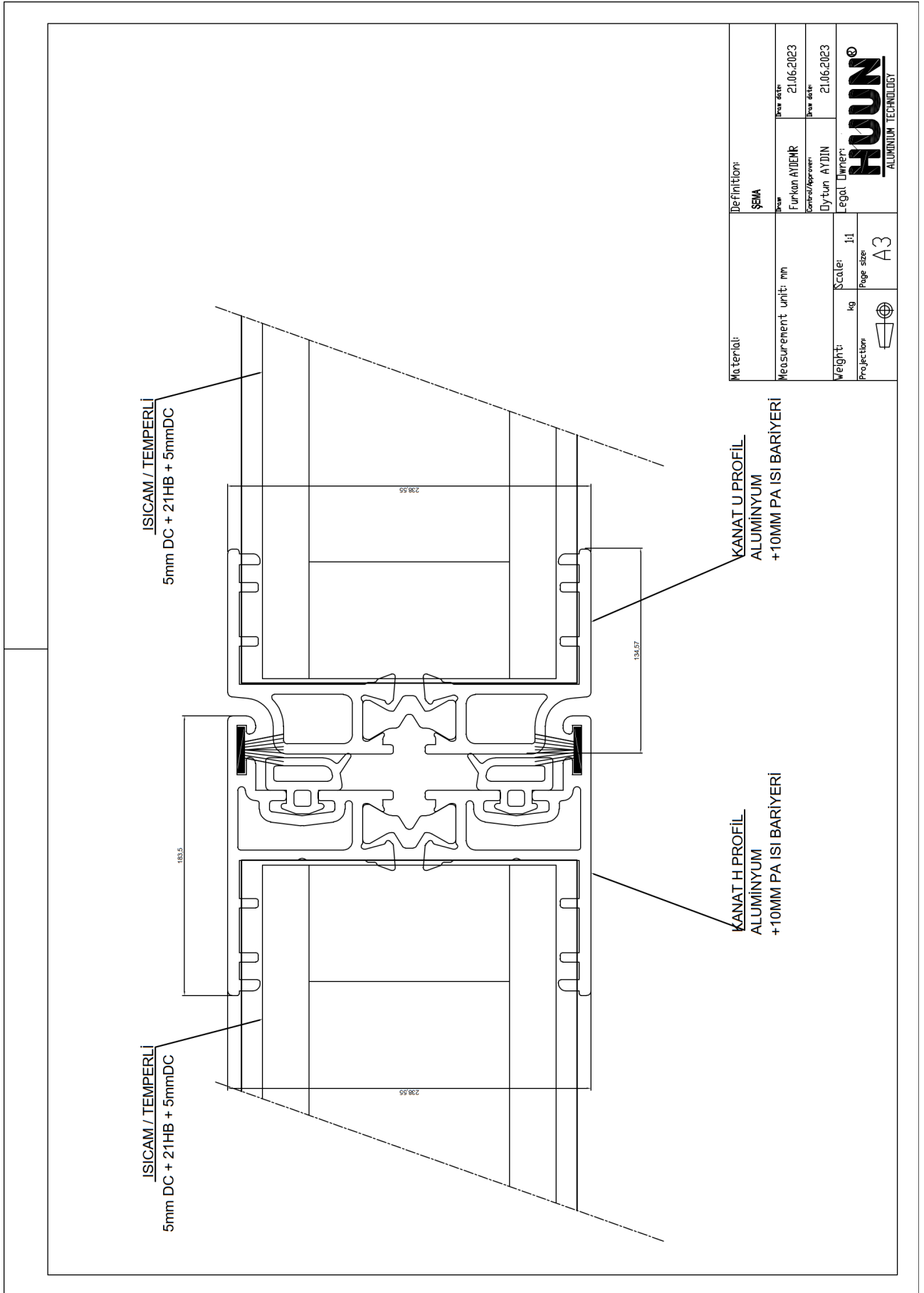

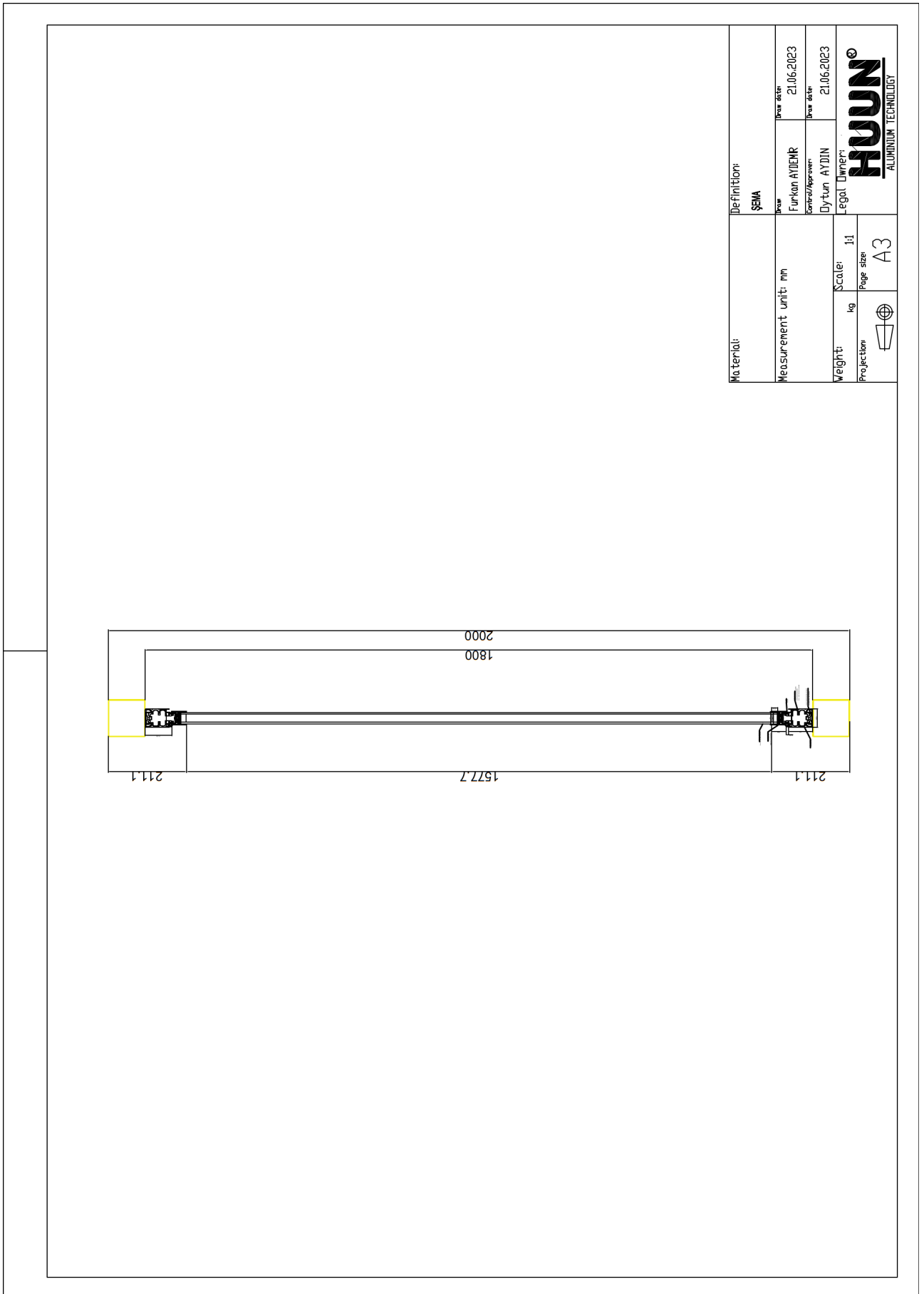

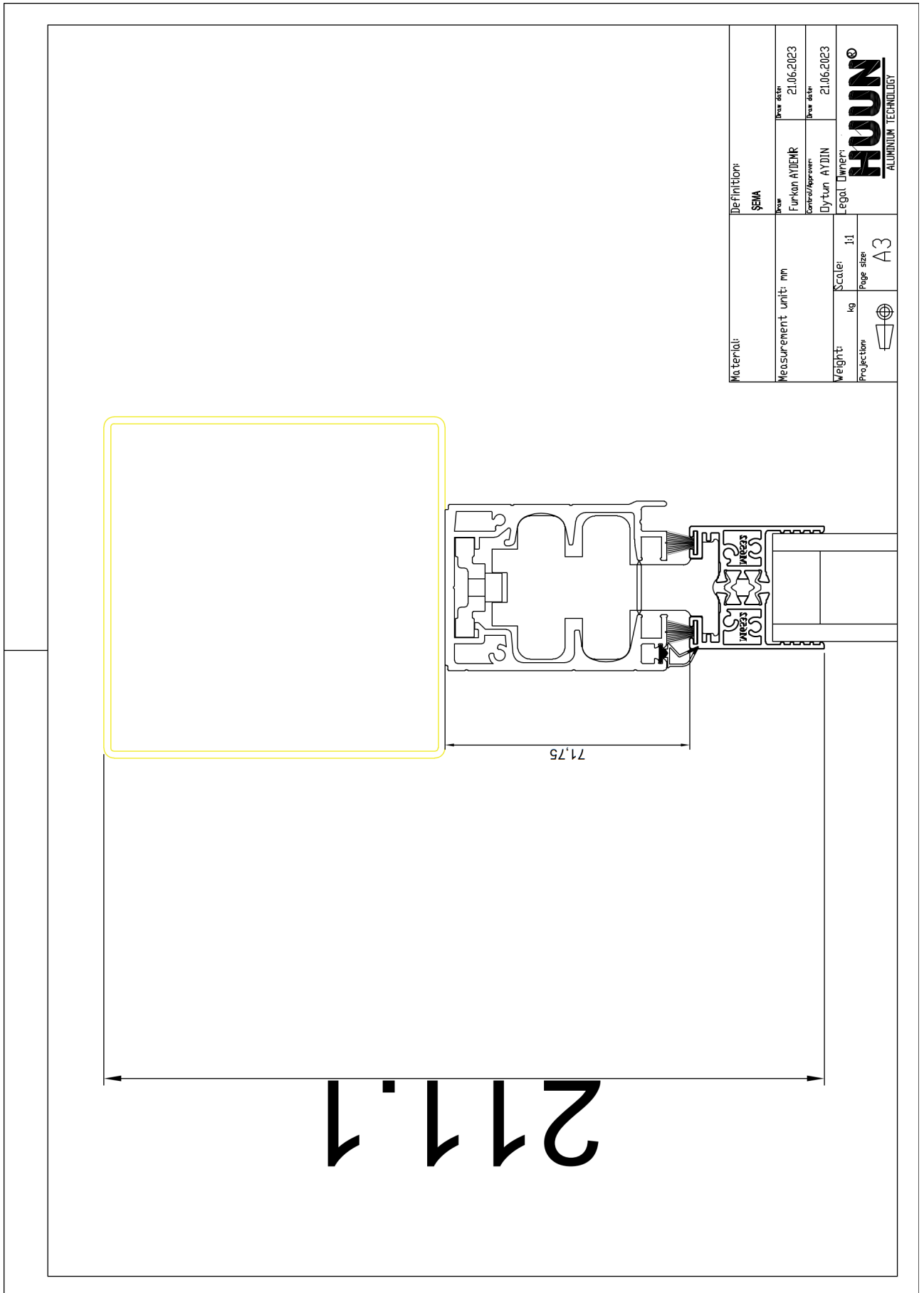

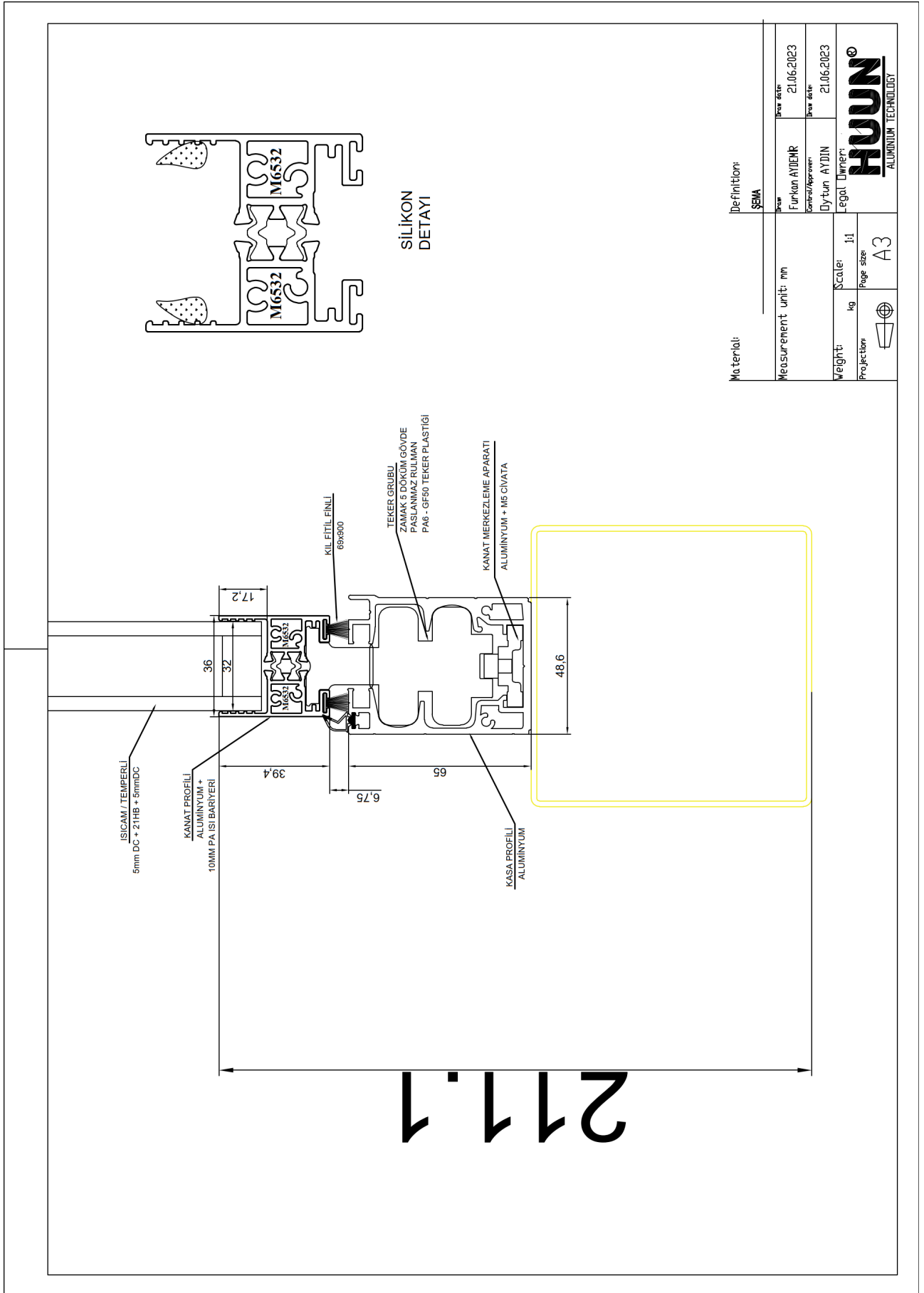

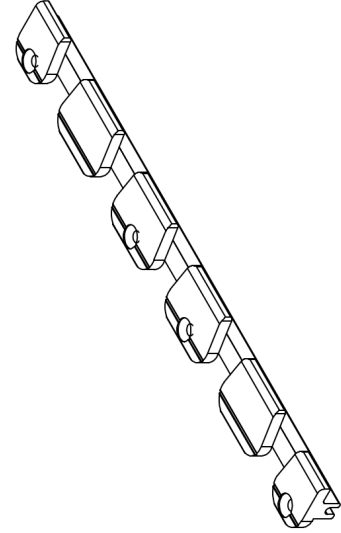
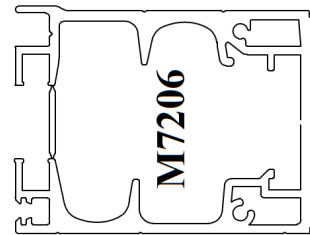
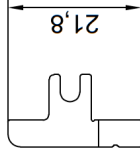
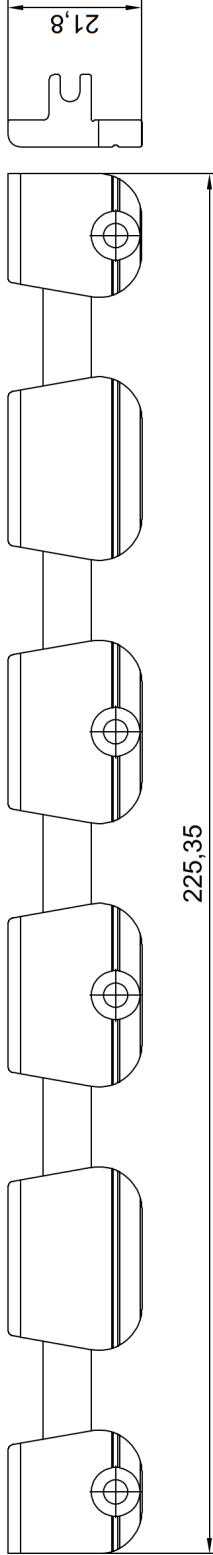
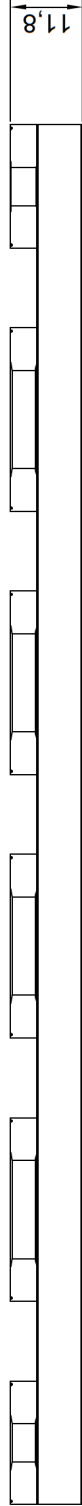

**KANAT KIZAKLAMA GÖVDE
(PROFİLDEN İŞLEME)
SİSTEM BAŞINA 1 ADET
KASAYA SONRADAN MONTAJ EDİLİR**



Material:	Definition:	DST KILAVUZ	
Measurement unit: mm	Drawn:	Furkan AVDEMİR	Drawn date: 19.01.2024
Weight: kg	Checked/Approver:	Dytun AYDIN	Drawn date: 19.01.2024
Scale: 1:1	Legal Owner:	HUUN® ALUMINIUM TECHNOLOGY	
Projection: 	Page size:	A4	

**KANAT KIZAK PİMİ (ZAMAK)
HAREKETLİ HER KANATTA 1 ADET ÜST
KISIMDA**

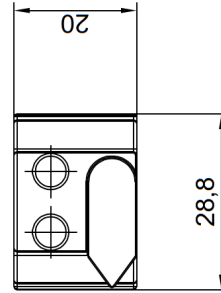
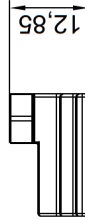
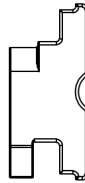
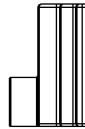
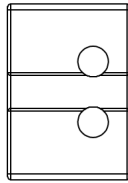
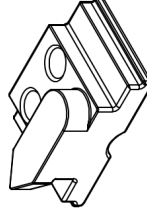
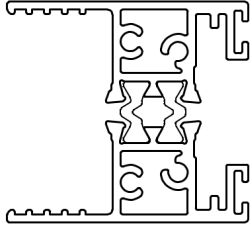

Material:	Definition:	kanat merkezlemel	
Measurement unit: mm	Drawn:	Furkan AVDEMİR	Draw date: 19.09.2022
Weight: kg	Checked/Approved:	Dytun AYDIN	Draw date: 19.09.2022
Projection:	Scale:	1:1	Legal Owners:
	Page size:	A4	HUUN ALUMINIUM TECHNOLOGY

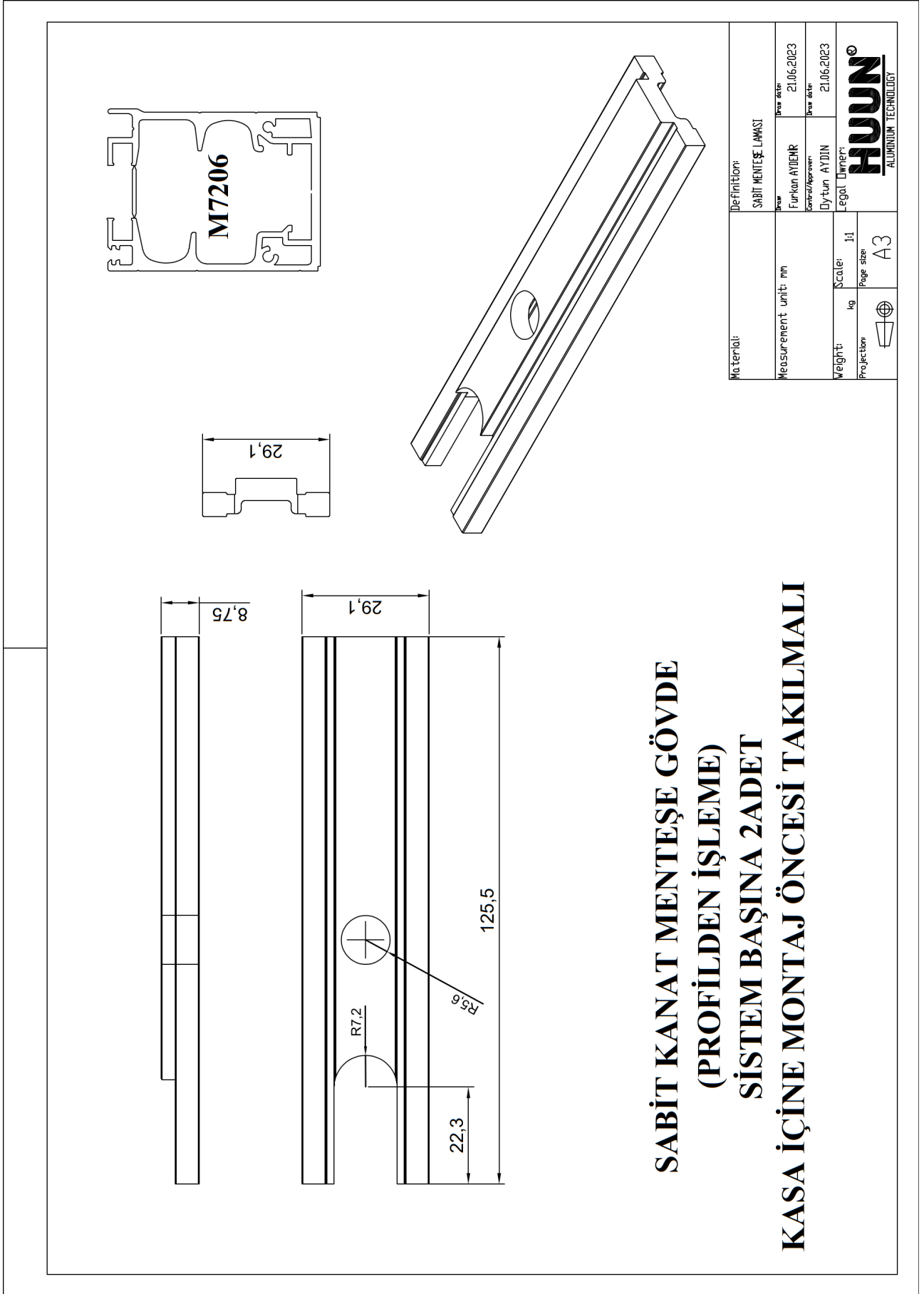

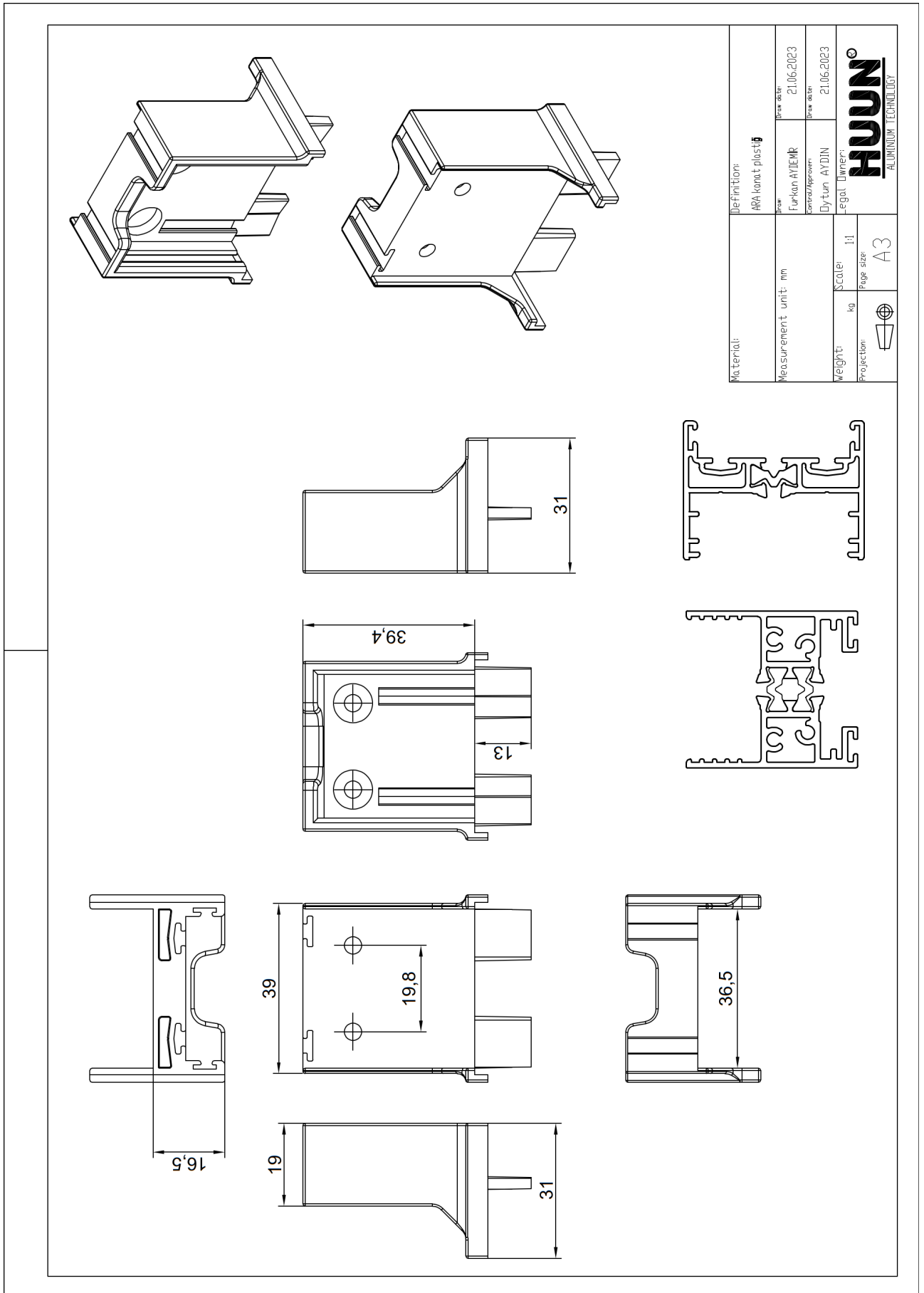

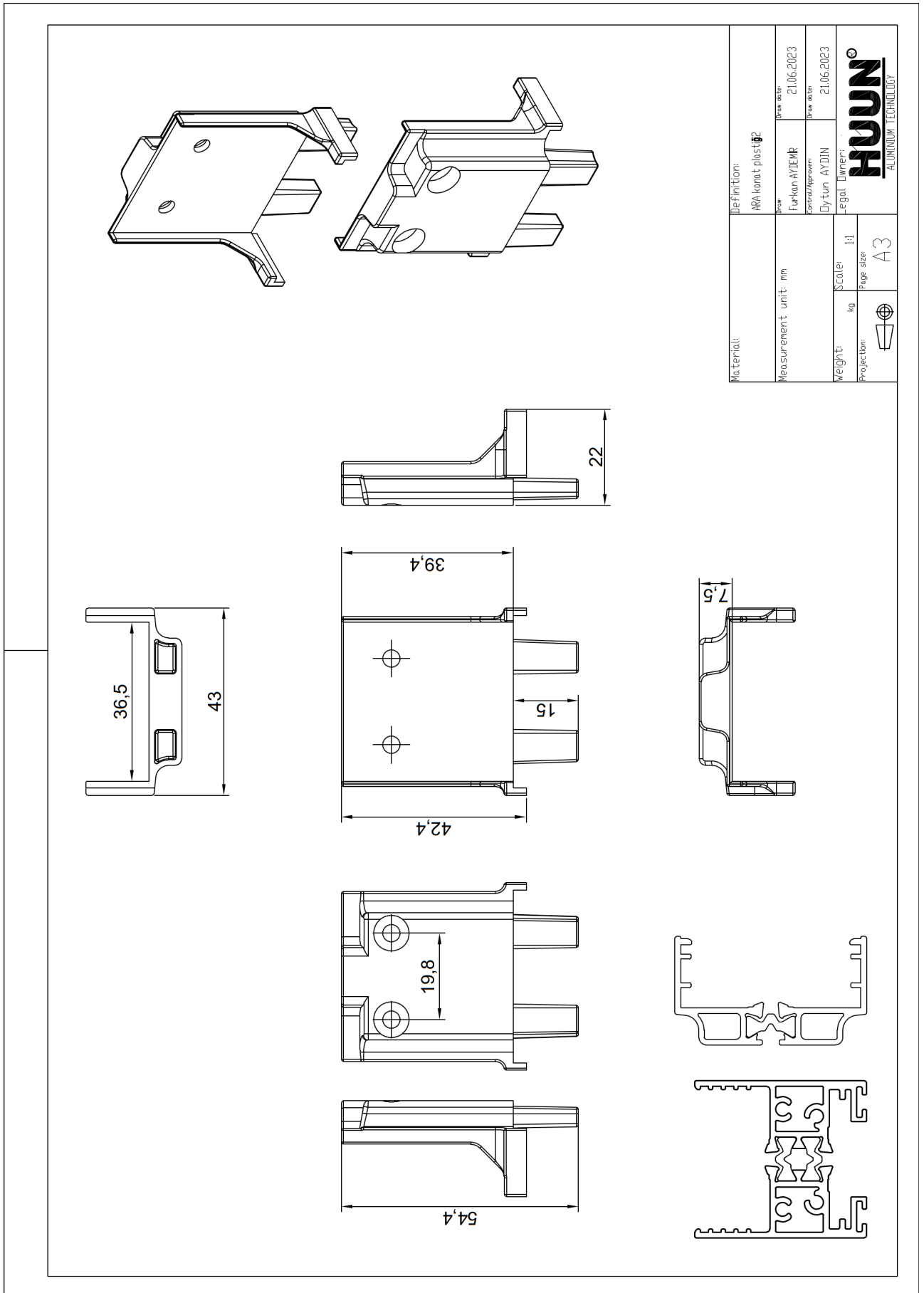

Material:	Definition:	Drawn by:	Drawn date:
	ARA konut plastik	Furkan AYDEMİR	21.06.2023
Measurement unit: mm	Checked/Approver:	Dytun AYDIN	21.06.2023
Weight: kg	Legal Owner:		
Projection:	Scale:	1:1	
	Page size:	A3	



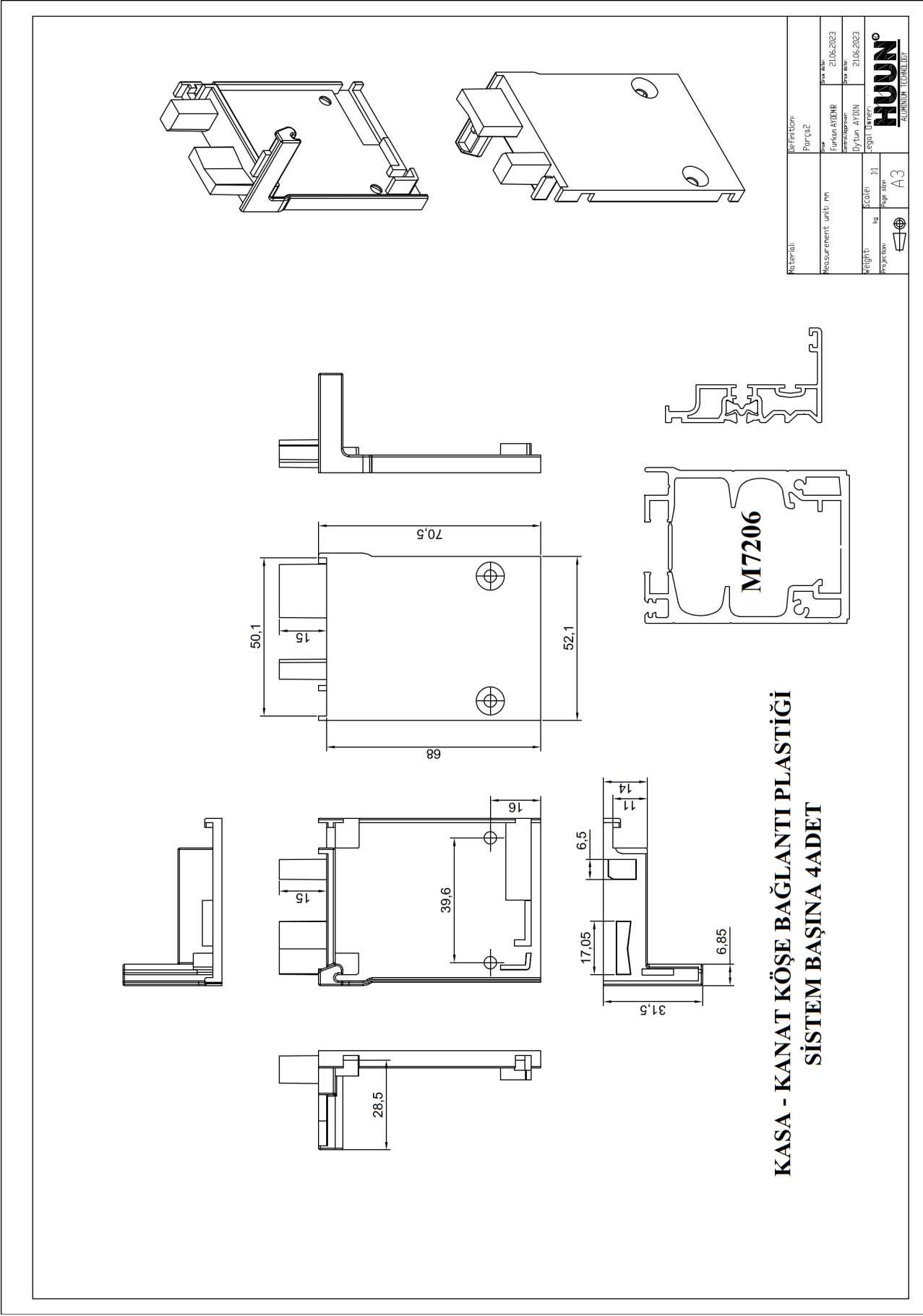

**SABİT KANAT MENTEŞE (ZAMAK)
SİSTEM BAŞINA 2ADET
SABİT KANATA MONTAJ EDİLİR**

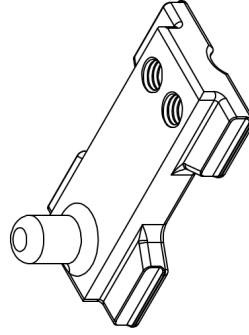
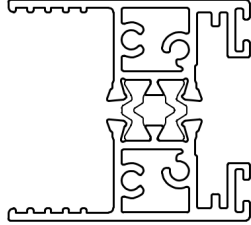
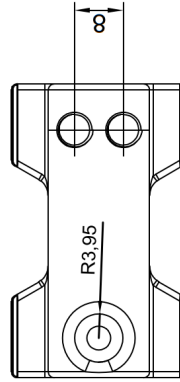
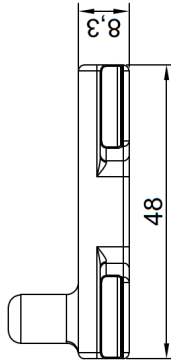
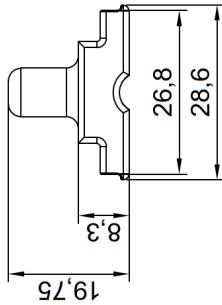
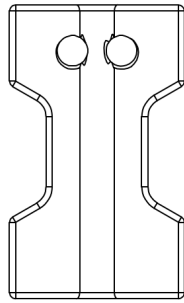

Material:	Definition:	Draw date:	Draw date:
	menteşe gövde	Furkan AYDEMİR	19.09.2022
Measurement unit: mm	Control/Approver:	Dytun AYDIN	19.09.2022
Weight: kg	Legal Owners:		
Scale: 1:1			
Page size: A4			
Projection:			

HUUN
ALUMINIUM TECHNOLOGY

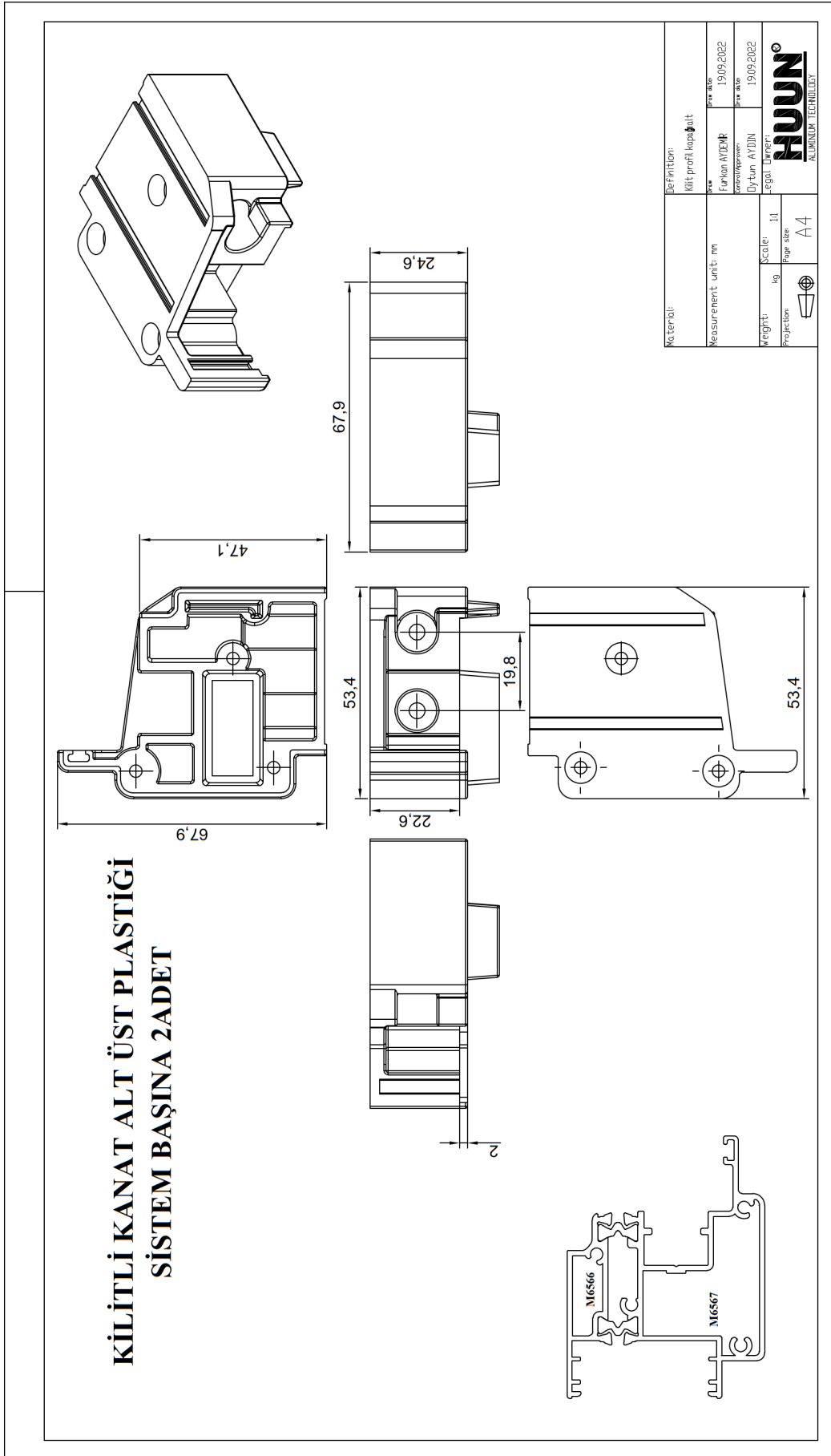

KİLİTLİ KANAT KARŞILIK ALT ÜST PLASTİĞİ SİSTEM BAŞINA 2ADET

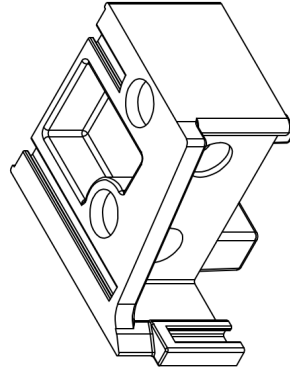
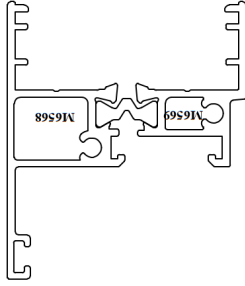
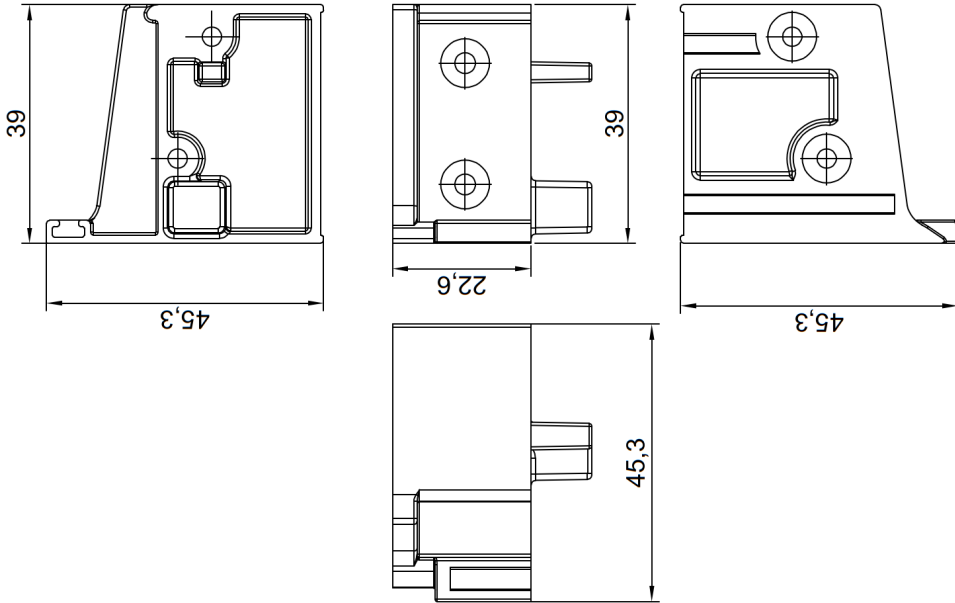

Material:	Definition:	Iskan Profil Kapama
Measurement unit: mm	Draw date:	19.09.2022
Weight: kg	Drawn/checked:	Dytun AYDIN
Projection:	Draw date:	19.09.2022
Scale: 1:1	Legal Owner:	HUUN® ALUMINIUM TECHNOLOGY
Page size: A4		

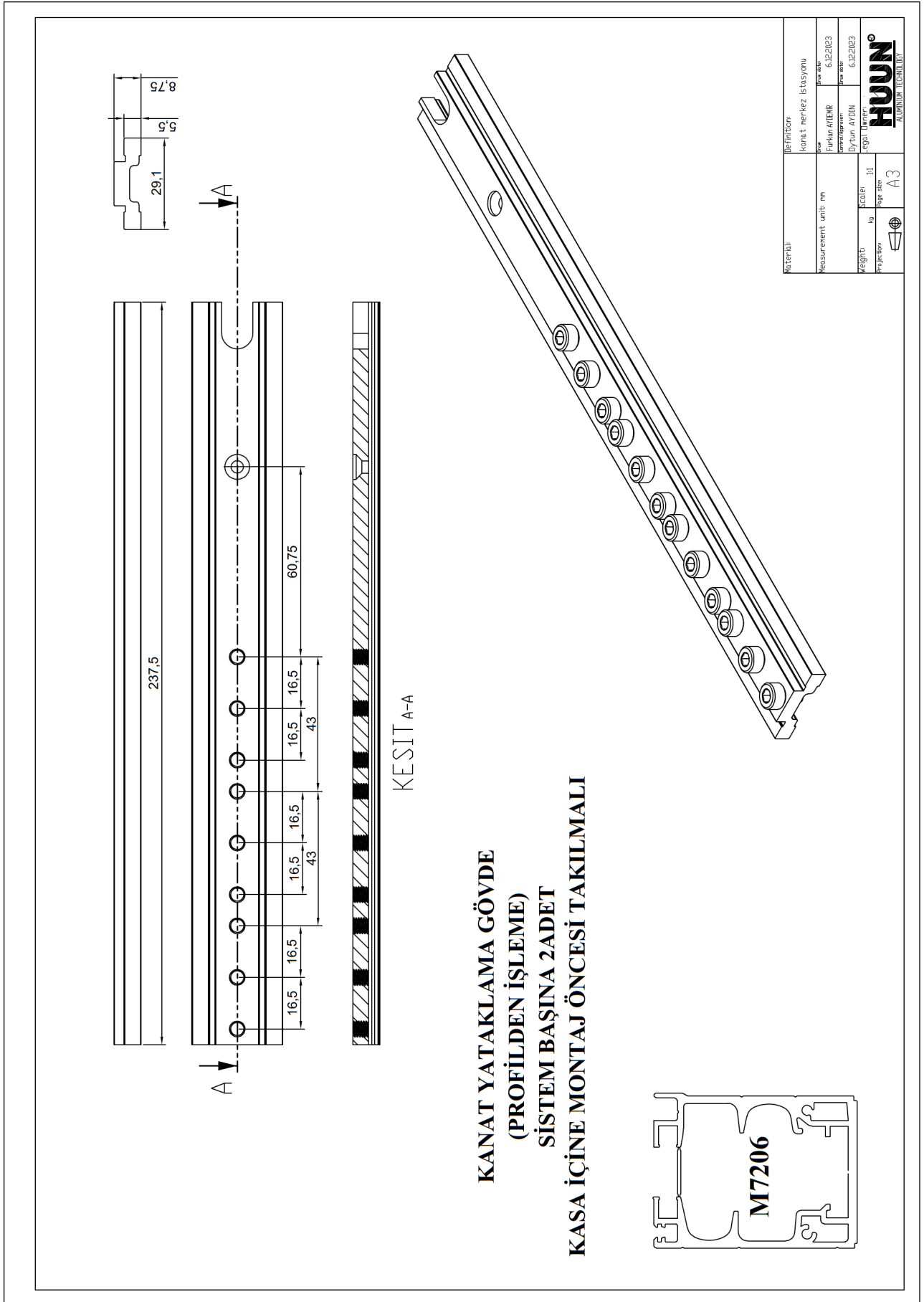

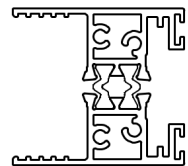
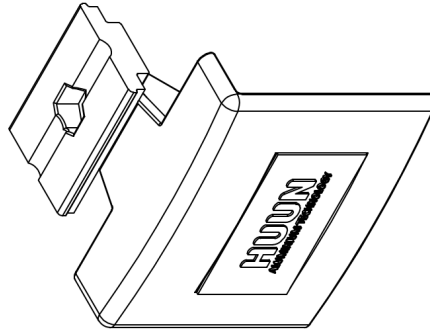
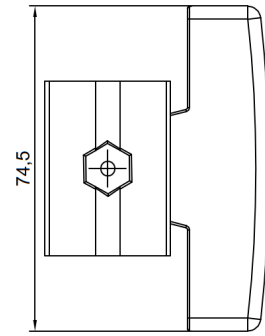
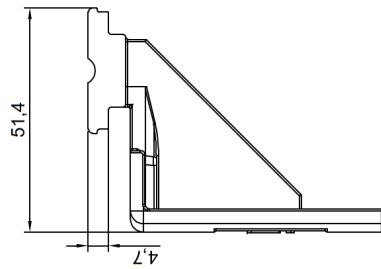
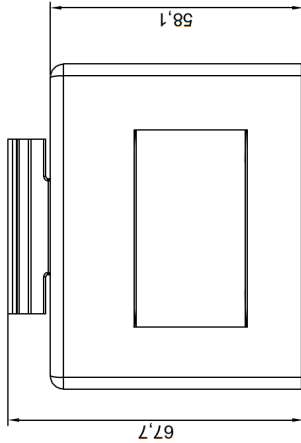
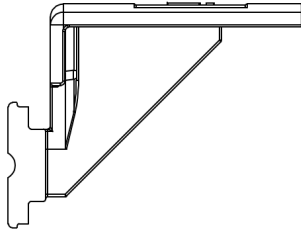
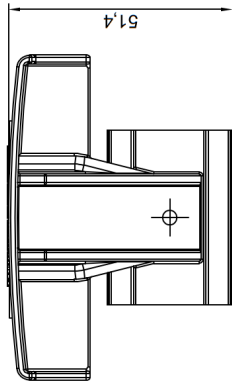

**ÇIKIŞ AĞZI KANAT PLASTİĞİ
 SİSTEM BAŞINA 2ADET**

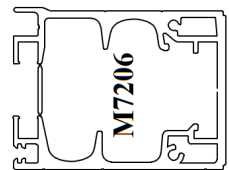
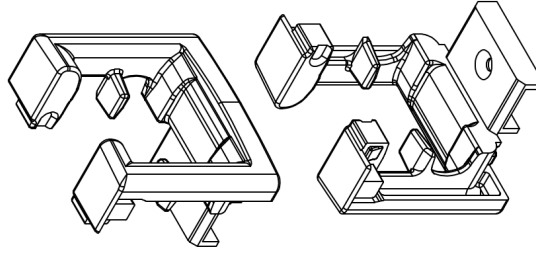
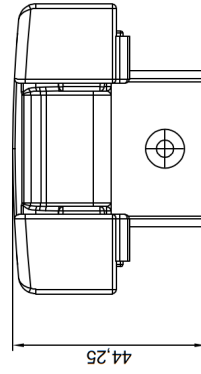
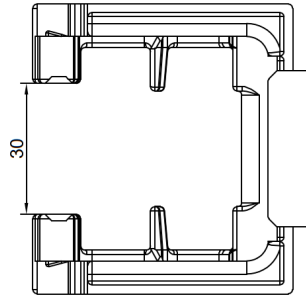
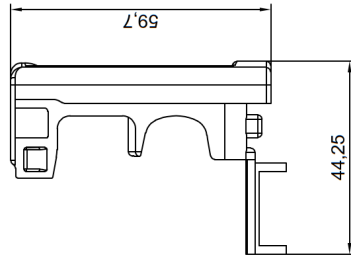
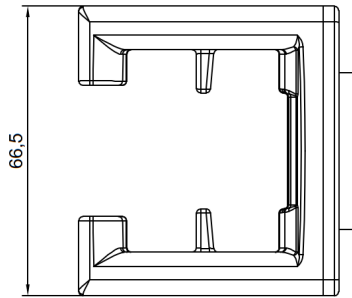
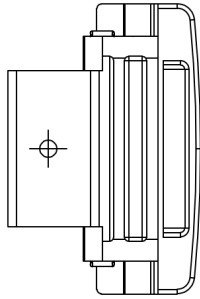

Material:	Definition:	KANAT GİRES KAPAĞI
Measurement unit: mm	Drawn:	Furkan AYDINR
Weight: kg	Checked/Approved:	Dytun AYDIN
Projection:	Page number:	11
	Page size:	A3
		
		HUON SÜMMERİYE TEKNOLOJİ

**ÇIKIŞ AĞZI GÖVDE PLASTİĞİ
 SİSTEM BAŞINA 2ADET**



Material:	Definition:	KAYIT ÇEKİŞİCİ	
Measurement unit: mm	Date:	Furkan AYDIN	6.12.2023
Weight: kg	Checked/Approved:	Diyadin AYDIN	6.12.2023
Projection:	Page number:	11	A3
			

**KANAT TEKER RULMAN KİLİTLİ
 (ZAMAK + RULMAN+ PLASTİK)
 HAREKETLİ KANAT BAŞINA 2 ADET**

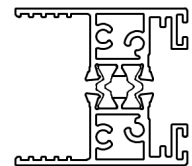
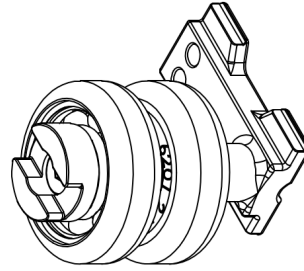
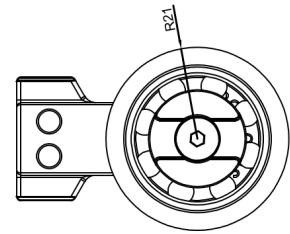
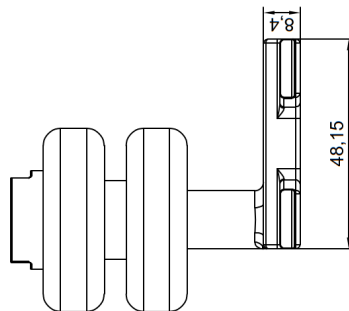
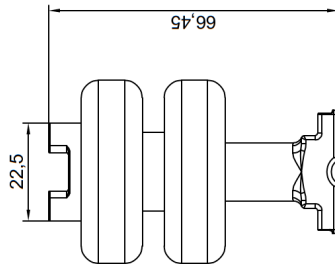
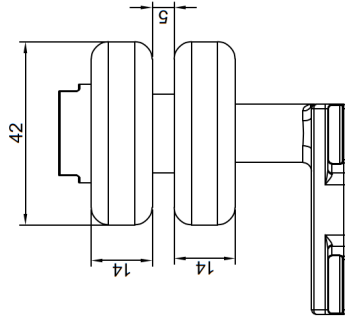
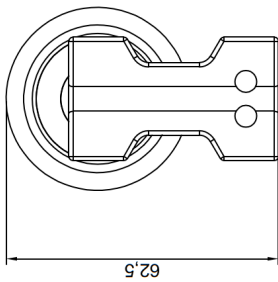

Material	Definition	Draw date
Measurement unit: mm	Tekelek Grubu Kilitli	6.12.2023
Weight: kg	Furkan AYDIN	Draw date: 6.12.2023
Projection	Dytun AYDIN	Draw date: 6.12.2023
Scale: 1:1	Page number: ...	
Page size: A3		



**KANAT TEKER RULMAN
 (ZAMAK + RULMAN+ PLASTİK)
 HAREKETLİ KANAT BAŞINA 2 ADET**

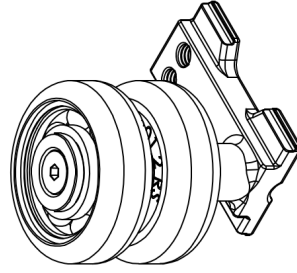
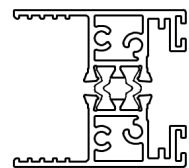
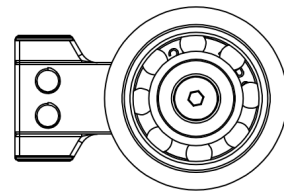
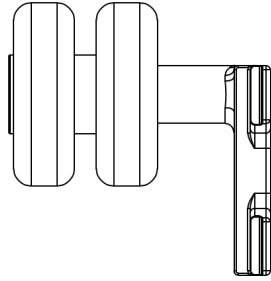
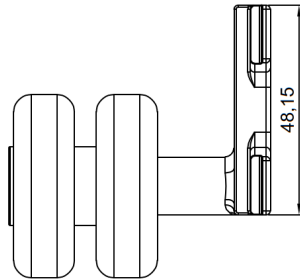
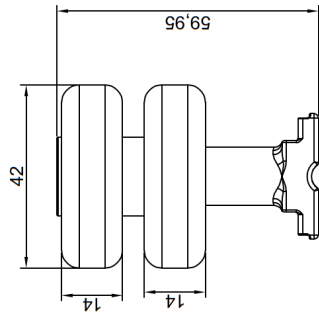
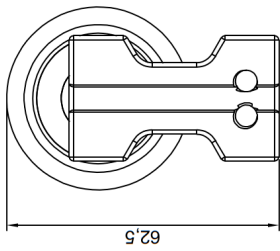

Material:	Definition:	Teleferik Grubu	
Measurement unit: mm	Size:	Funkon AYDHR	Size date: 6.12.2023
Weight: kg	Checked:	Dytun AYDIN	Size date: 6.12.2023
Projection:	kg	Page size:	A3
		HUHN TEKNIKALYK	

Change Index

Version No.	Date of revision	Page / Section	Original contents	New contents
1.en	12.02.2024	-	First version	-

The last document replaces the previous documents.